

Operator's manual
AR19
AR25

Please read these instructions carefully and make sure
you understand them before using the machine.



English

TABLE OF CONTENTS

Operator's Manual for Lawn Aerator AR19, AR25

Introduction	2	Replacing the air filter	25
Congratulations	2	Cleaning the sludge reservoir	26
Use	2	Idle adjustment	26
Insure your machine	2	Adjusting the throttle cable	27
Good service	2	Replacing the throttle cable	27
Serial number	2	Ignition system	28
What is aeration?	3	Replacing the engine	29
When should I use the removable weights?	3	Replacing the clutch cable	29
Should I water the lawn before aeration?	3	Replacing and adjusting the drive belt	30
Symbols and decals	4	Cam lock for the handle	31
Decals and machine-bound instructions	4	Wheels	32
Location of decals	5	Tines and tine shaft	34
Translation of instructions	5	Chain	36
Safety instructions	6	Cleaning and washing	37
General	6	Two minute rule	37
Children	7	Lubrication	38
Preparations	8	Lubrication schedule	38
Running	9	General	39
Movement/Transport	10	Engine oil	39
Storage	10	Oil change in reduction gear 1:6	40
Fuel system	11	Chain	41
Maintenance	12	Rear wheels	41
Presentation	13	Tines	41
Main components and operating instruments	13	Links and joints	41
Engine	14	Adjustment for rear wheel depth/stability	42
Controls on the handle	18	Cam lock for the handle	42
Adjusting the rear wheels	19	Handles with controls	42
Weights	19	Assembly instructions	43
Running	20	Assembly – Initial start-up	43
Starting the engine	20	Storage	45
Cutting the engine	21	Winter storage	45
Aeration tips	22	Service	45
Before you start	22	Wiring diagram	46
Aeration	22	Troubleshooting	47
Turning and maneuvering the lawn aerator	23	Technical data	48
Operating on hills	23	Service journal	49
Maintenance	24	Delivery service	49
Maintenance schedule	24	After the first 20 hours	49

INTRODUCTION

Congratulations

Thank you for purchasing a Husqvarna lawn care product. Through your confidence in us, you have chosen an exceptionally high quality product.

This manual is a valuable document. It describes your new Husqvarna machine. Read the manual carefully before attempting to use the machine. Following the instructions (use, service, maintenance, etc.) can considerably increase the lifespan of your machine and even increase its resale value. Please contact your dealer for more information.

If you sell your Husqvarna machine, make sure to give the operator's manual to the new owner.

Use

The lawn aerator is used to aerate the turf in your lawn. Do not use the machine until you have read the operator's manual carefully, particularly the safety instructions.

Insure your machine

Contact your insurance company to check on insurance coverage for your new machine. You should have all-inclusive insurance for liability, fire, damage and theft.

Good service

Husqvarna's products are sold all over the world and only in specialized retail trade with complete service. This ensures that you as a customer receive only the best support and service. Before the machine was delivered it underwent inspection and was adjusted by your dealer. When you need spare parts or support in service questions, guarantee issues, etc., please consult the following professional:

This Operator's Manual belongs to machine with serial number:	Engine number:

Serial number

The machine's serial number can be found on the printed plate attached to the rear side panel of the machine. The plate includes the following information:

- The machine's type designation (MODEL).
- The machine's serial number (S/N).

Please state the type designation and serial number when ordering spare parts.

The engine's serial number is punched in the crankcase above the oil drainage screw.

The engine type is specified on the crankcase under the air filter but also appears on the decal on the starter.

Please state these when ordering spare engine parts.

INTRODUCTION

What is aeration?

For your lawn to grow at its best, the roots need to be surrounded by air pockets in the soil so that oxygen, water and nutrients can be absorbed. Air pockets in the lawn shrink as the earth is compacted by pedestrian traffic, rainfall, irrigation, or construction and landscaping work. Mechanically removing small plugs (cores) of soil and thatch increases the quantity of air in the soil considerably. In this manner, the aeration process promotes new root growth and improves the lawn's ability to absorb water and nutrients. The end result is a healthier, more beautiful lawn.

When should I use the removable weights?

The soil conditions dictate whether extra machine weight will be required for effective aeration. The weights are provided to give you added control and greater tine penetration.

Should I water the lawn before aeration?

Normally, it is not necessary to water the lawn before aerating. In extreme conditions, such as highly compacted clay soil, a simple test can be used to determine whether you need to water before aerating. Use a garden spade, weeding tool or a large screwdriver to test the ground's hardness. You should be able to push the tool 5 - 7.5 cm into the ground with little effort. If you are unable to do so, watering is advisable. Watering the day before should give sufficient time for the soil to absorb the moisture. Use your hand tool to gauge the effectiveness of your watering.

SYMBOLS AND DECALS



Used in this publication to notify the reader of a risk of **personal injury**, particularly if the reader should neglect to follow instructions given in the manual.

Used in this publication to notify the reader of a risk of **material damage**, particularly if the reader should neglect to follow instructions given in the manual. Used also when there is a potential for misuse or misassembly.

Decals and machine-bound instructions

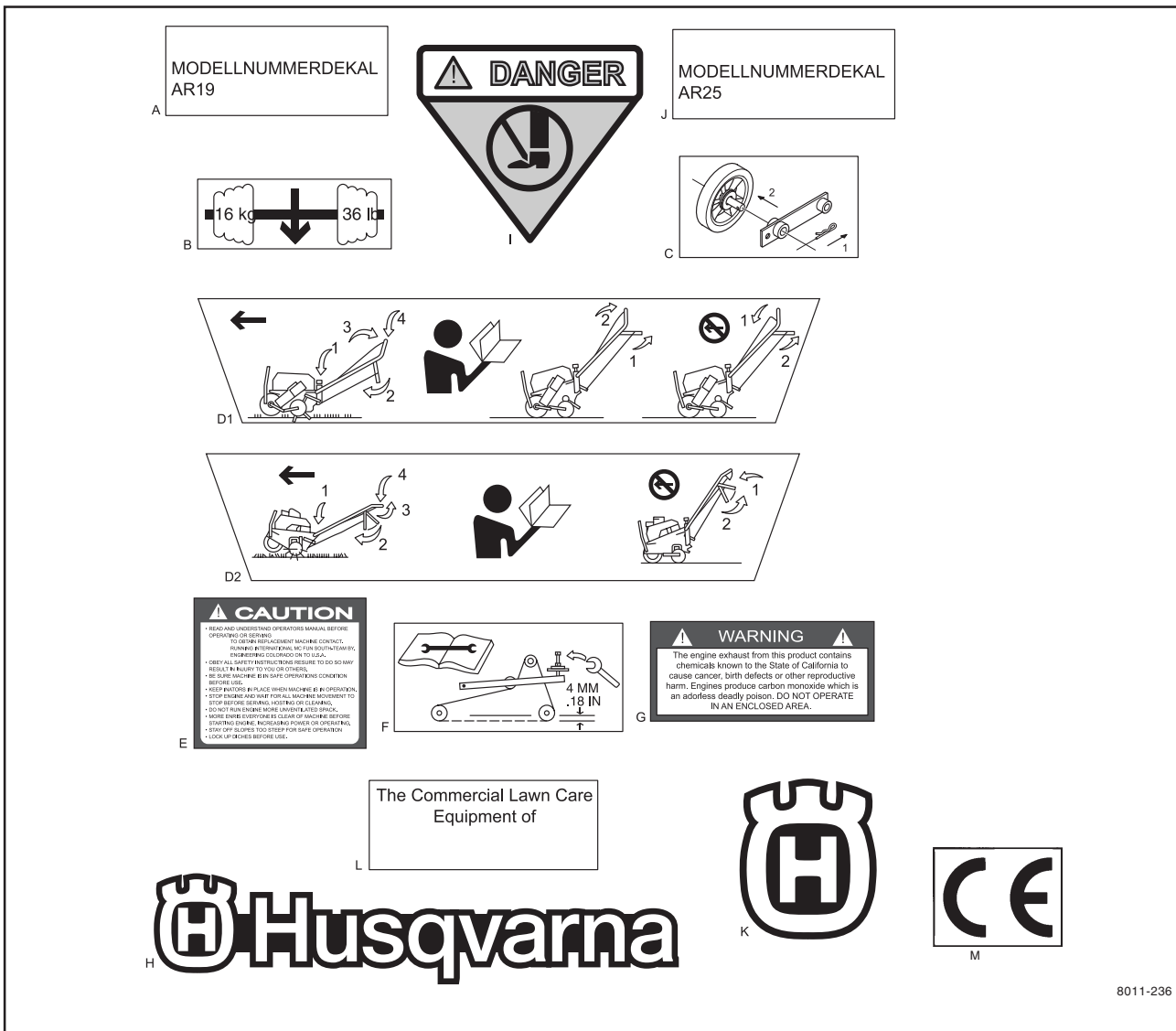

A. Model designation AR19

B. Weights

C. Wheel removal (AR25)

D1. Operating instructions (AR19)

D2. Operating instructions (AR25)

E. Caution list

F. Chain tension

G. WARNING carbon monoxide

H. Husqvarna logotype

I. DANGER Mind your feet

J. Model designation AR25

K. Husqvarna crown

M. European standard for machine safety

SYMBOLS AND DECALS

Location of decals

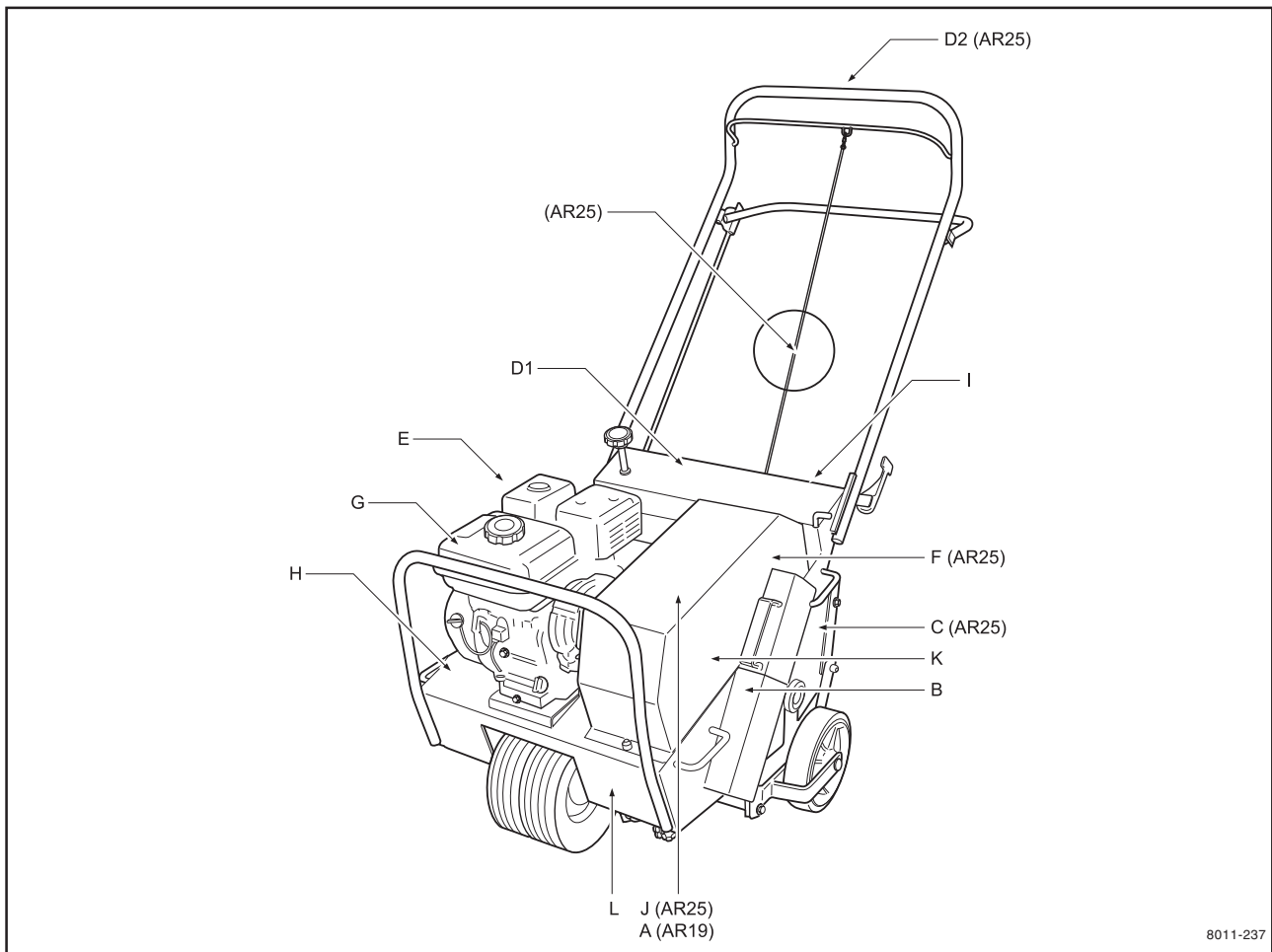

Translation of instructions

Decal E

Important information

Read and make sure you understand the Operator's Manual before use or maintenance.

To obtain a replacement manual, please contact your dealer.

Observe all safety instructions; otherwise you may injure yourself or others around you.

Make sure that the machine is in serviceable condition prior to use.

Make sure that all protective devices are in place when the machine is in use.

Stop the engine and wait until all machine movement comes to a standstill before service, adjustment or cleaning.

Do not run the engine in poorly ventilated spaces.

Make sure nobody is in the vicinity of the machine before starting and during use.

Avoid slopes that are too steep to use the machine safely.

Clear any debris from the lawn prior to use.

Decal G

Warning

Engine exhaust, some of its constituents and certain vehicle components contain or emit chemicals considered by the State of California to cause cancer, birth defects or other reproductive harm. The engine emits carbon monoxide, which is a colorless, poisonous gas. Do not use the machine in enclosed spaces.

SAFETY INSTRUCTIONS

General

The object of this manual is to help you use your Husqvarna machine more safely and to give you information about how to maintain your machine. Please read the manual carefully before attempting to use the machine.

If after reading the operator's manual you are still unsure about the safety risks associated with use of the machine, you should not use the machine. Please contact your dealer for more information.

These safety instructions only address the basics for safe use. It would be impossible in the safety instructions to describe all possible risk situations that could arise when using the machine. You can, however, prevent accidents by always using common sense.

To obtain extra copies of the operator's manual, please contact your dealer.



WARNING!

Under no circumstances may the original design of the machine be modified without written approval from the manufacturer. Such modifications not only affect the performance and durability of the machine but may even pose a safety risk for users and those in the vicinity. Unauthorized modifications to the design of the machine may absolve the manufacturer from liability for any resulting personal injury or property damage. Modifying the machine without written approval from the manufacturer may void the guarantee.

IMPORTANT INFORMATION

Do not use the machine until you have read the operator's manual carefully and understand the instructions given. All maintenance work or adjustments not described in this manual must be performed by an authorized Husqvarna service workshop.

- Read this manual carefully and make sure you understand it before using the machine or performing any maintenance. If the user cannot read this manual, it is the responsibility of the machine owner to explain the contents to the user.
- Follow all safety instructions. Failure to do so may result in injury to yourself or others.
- Accident prevention regulations, other general safety regulations, occupational safety rules and traffic regulations must be followed without fail.
- All users shall be trained in use of the machine. The owner is responsible for training users.
- Engage an authorized Husqvarna workshop for all service and repairs not described in this manual.

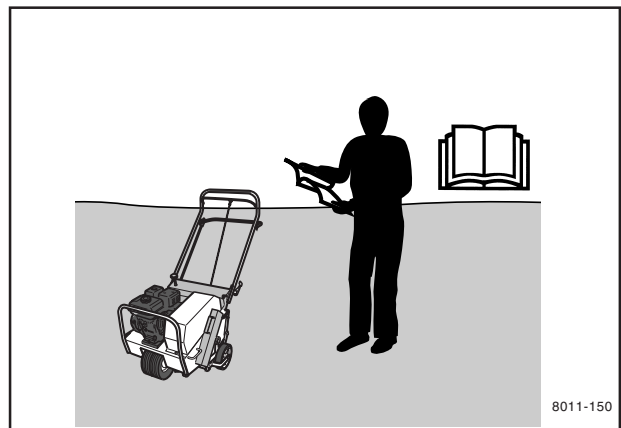

Read this manual carefully before starting the machine.

SAFETY INSTRUCTIONS

- Check that all safety decals are in place. See the chapter "Symbols and decals".
- Learn how to use the machine and its controls safely and learn to recognize the safety decals.
- Check that the machine is in serviceable condition prior to use; see the chapter "Maintenance/Maintenance schedule".
- Only use the machine in daylight or in other well-lit conditions. Keep the machine a safe distance from holes or other irregularities in the ground. Pay attention to other possible risks.
- Only allow the machine to be used by adults who are familiar with its use.
- Never allow children or persons not trained in the use of the machine to use or service it. Local laws may regulate the age of the user.
- People and animals can distract you causing you to lose control of the machine. For this reason, you should always concentrate and focus on the task at hand.
- Make sure that other people are nearby when you are using the machine so that you can call for help should an emergency arise.
- Never leave the machine unsupervised with the engine running.
- Husqvarna original spare parts are designed and specified to maintain high quality and correct fit for optimal durability and lifespan. From a safety point of view, you should only use Husqvarna original spare parts.
- The machine is tested and approved only with the equipment originally provided or recommended by the manufacturer.

Children

- Serious accidents may occur if you fail to be on guard for children in the vicinity of the machine. Never assume that children will stay put where you last saw them.
- Keep children away from the work area and under close supervision by another adult.
- Keep an eye out and shut off the machine if children enter the work area.
- Never allow children to operate the machine.
- Be particularly careful near corners, bushes, trees or other objects that block your view.
- Keep children away from the machine.



WARNING!
Overexposure to vibration can lead to circulatory or nerve damage, particularly in people who have impaired circulation. Contact your doctor if you experience symptoms that could have been caused by overexposure to vibration. Examples of common symptoms include numbness, pain, muscle weakness, change of skin color, or an uncomfortable tingling sensation. These symptoms appear most frequently in the fingers, hands or wrists.

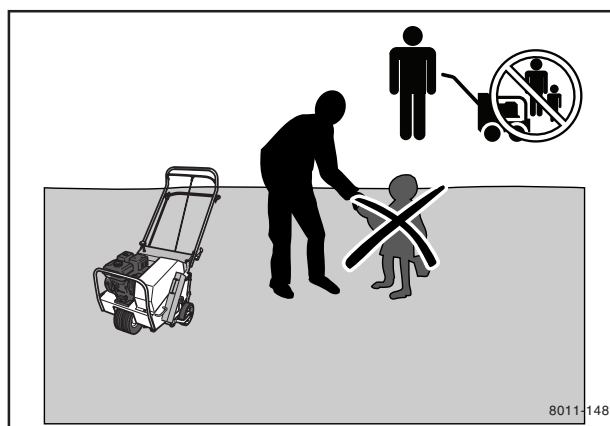

Keep children away from the work area.

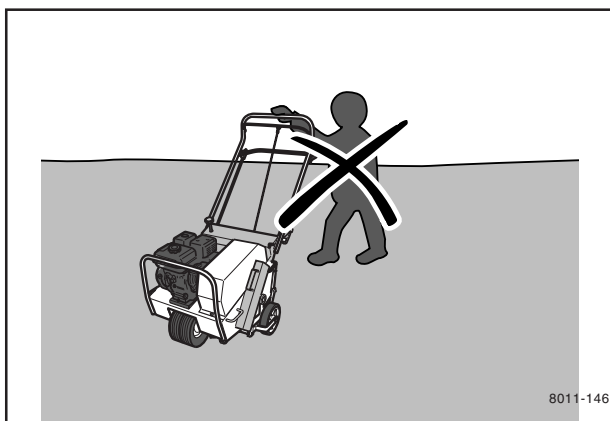

Keep children away from the machine.

SAFETY INSTRUCTIONS

Preparations

- Make sure that you always have first aid equipment close at hand when using the machine.
- Make sure nobody else is in the vicinity of the machine when you start the engine, engage the drive or run the machine.
- Make sure animals and people maintain a safe distance from the machine.
- Clear the area of objects such as stones, toys, steel wire, etc. that may become caught in moving machine parts and thrown out.
- Find and locate all fixed objects in the ground, such as sprinkler systems, poles, water valves, bases for washing lines, etc. Be certain to check for hidden electrical cables or similar in the surface of the lawn. Always run the machine around these objects. Never intentionally run the machine over foreign objects.
- Make sure all guard plates and protective cowlings are in place and intact when using the machine.
- Never use the machine when barefoot. Always wear protective shoes or protective boots with anti-slip and preferably with steel toes.
- Wear approved ear-protection when running the machine. Ask your dealer about approved ear-protection.
- Make sure no clothing, long hair or jewelry can fasten in moving machine parts.

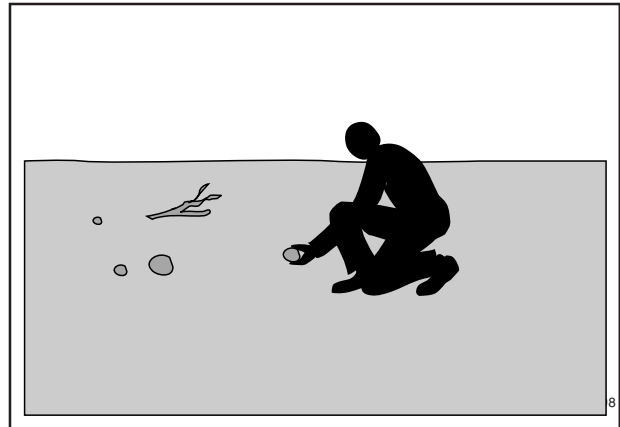

Clear the area of all extraneous objects that could be thrown out by the machine's moving parts.

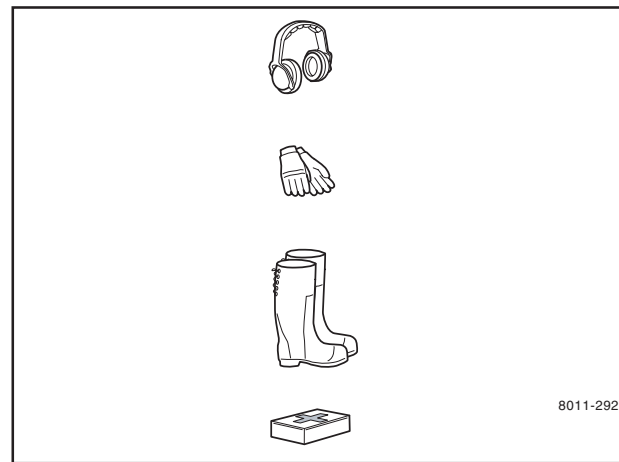

Protective equipment.



WARNING!

Always use approved protective clothing and approved protective equipment when using the machine. Protective clothing and protective equipment cannot eliminate the risk of accidents but wearing proper clothing and the correct equipment will reduce the degree of injury should an accident occur. Ask your dealer about approved protective clothing and approved protective equipment recommended by Husqvarna.

SAFETY INSTRUCTIONS

Running



WARNING!

The engine can become very hot. To avoid being burned, you must turn off the engine and wait until all parts have cooled before touching the engine.

- Do **not** use the machine on grades of more than 20°.
- Slow down and be especially careful in slopes. Make sure to run the machine in the recommended direction in slopes; see the chapter "Running/Operating on hills". Be careful when working close to sudden changes in level.
- Do **not** use the machine if you are tired, if you have consumed alcohol, or if you are taking other drugs or medication that can affect your vision, judgment or co-ordination.
- Never use the machine indoors or in spaces lacking proper ventilation.
- Do not use the machine on any surface other than grass.
- Only use the machine for aerating lawns. It is not intended for any other use.
- Make sure you have a proper foothold when using the machine, particularly when backing. Walk, don't run. Never work on wet grass. Poor footholds may cause you to slip.
- Keep your hands and feet away from the work tools.
- Mind you keep your hands and feet away from moving parts.

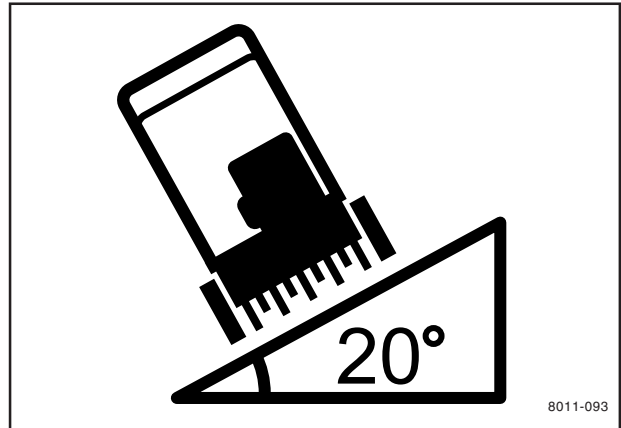

Do not use the machine on grades of more than 20°.



The engine exhaust is poisonous. Never run the engine indoors.



Mind you keep your hands and feet away from moving parts.



WARNING!

Engine exhaust, some of its constituents and certain vehicle components contain or emit chemicals considered to cause cancer, birth defects or other reproductive harm. The engine emits carbon monoxide, which is a colorless, poisonous gas. Do not use the machine in enclosed spaces.

SAFETY INSTRUCTIONS

- Smoking, open flames or sparks in the vicinity of the machine are **strictly** forbidden. Gasoline is extremely flammable and can result in personal injury or fire.
- Stop and inspect the equipment if you run over or into anything. If necessary, make repairs before beginning again.
- Whatever happens, you should always park the machine on even ground, disengage the drive, turn off the engine and wait until all moving parts have stopped before leaving the operating position behind the machine.

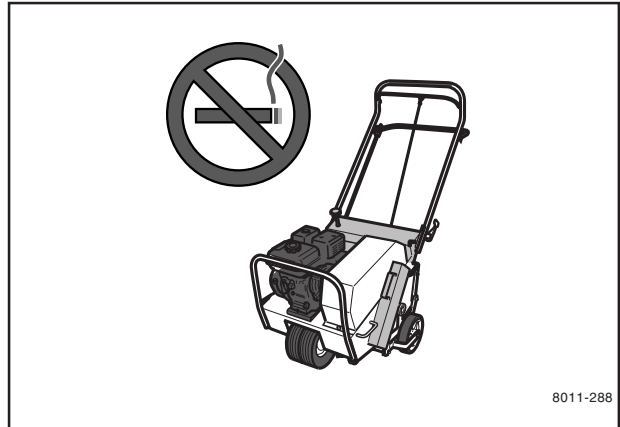

Smoking near the machine is **strictly** prohibited.

Movement/Transport

- To turn and steer the machine, press down on the handle and turn on the rear wheels.
- Turn off the engine and allow it to cool at least 2 minutes before transport.
- Collapse the handle if the machine is equipped with a collapsible handle.
- Do **not** lift the lawn aerator by hand. Use a lifting crane or other suitable equipment to load the machine.
- Be careful and use safe lifting and moving techniques when loading/unloading the machine.
- Fasten the machine properly in place with approved fasteners, such as tension belts, chains or rope. Always check that you are in compliance with applicable traffic regulations before transporting the machine.

Storage

- Allow the engine to cool before storing the machine. Never store the machine near open flame.
- Store the machine and fuel in such a way that there is no risk that leaking fuel or fumes can come in contact with flames or sparks from electrical machines, electric engines, relays, switches, boilers or similar.
- Store the machine in a locked space away from children and adults untrained in use of the machine.

SAFETY INSTRUCTIONS

Fuel system



WARNING!

Gasoline and gasoline fumes are poisonous and extremely flammable. Be especially careful when handling gasoline, as carelessness can result in personal injury or fire.

- Only store fuel in containers approved for the purpose.
- Never remove the fuel cap and fill the fuel tank while the engine is running.
- Always stop the engine when refueling.
- Do not smoke when filling the gasoline tank and do not pour gasoline in the vicinity of sparks or open flame.
- Never fill the fuel tank indoors.



Never fill the fuel tank indoors.

- Before starting the machine after refueling, it should be moved at least three meters from the location where it was filled.
- Turn off the fuel supply for storage or transport.
- If leaks arise in the fuel system, the engine must not be started until the problem has been resolved.

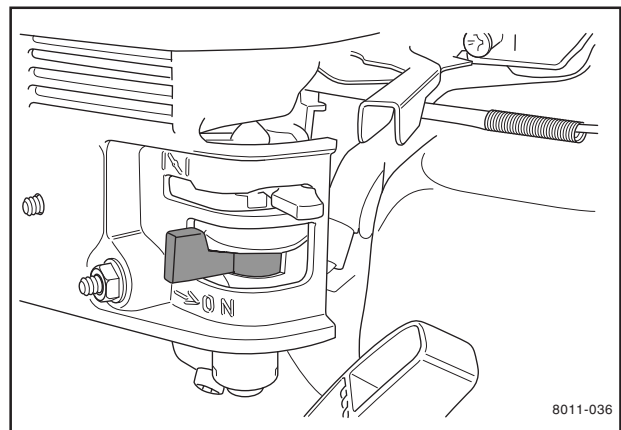

Turn off the fuel supply for storage or transport.

- Check the fuel level before each use and leave space for the fuel to expand, because the heat from the engine and the sun may otherwise cause the fuel to expand and overflow.
- Avoid overfilling. If you spill gasoline on the machine, wipe up the spill and wait until it has evaporated before starting the engine. If you spill gasoline on your clothing, change your clothing.

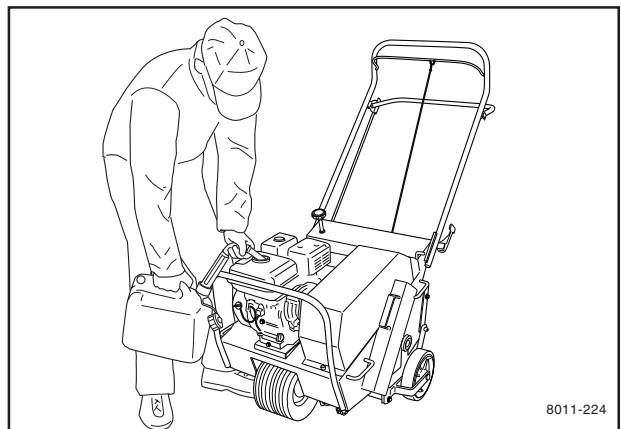

Check the fuel level before each use.

SAFETY INSTRUCTIONS

Maintenance

- Never allow persons not trained in the use of the machine to perform service on it.
- Always park the machine on even ground before performing maintenance or making adjustments.
- Never make adjustments with the engine running.
- Disengage the drive units, shut off the engine and wait until all moving parts come to a complete stop before making adjustments, performing maintenance or cleaning the machine.
- Disconnect the spark plug cable before beginning repair work.
- Keep all components in serviceable condition and make sure all nuts, bolts, etc. are tight. Replace worn or damaged decals.
- Be careful when checking work tools. Use gloves when performing maintenance work.
- Do not disassemble the engine. This may invalidate your guarantee. Please contact your dealer if you have any questions regarding service or guarantee matters. Follow all maintenance instructions.
- Do not change the setting of governors and avoid running the engine with overly high RPMs. If you run the engine too fast, you risk damaging the machine components.
- Do not modify safety equipment. Check regularly to be sure it works properly. The machine must not be run with defective or disassembled safety equipment.
- The muffler is designed to maintain sound levels at an approved level and to keep direct exhaust away from the user. Exhaust gases from the engine are extremely hot and may contain sparks that can cause fires or burn the user.
- Never use a machine with a defective muffler.
- Reduce the risk of fire by removing grass, leaves and other debris that may have fastened in the machine. Allow the machine to cool before putting it in storage.

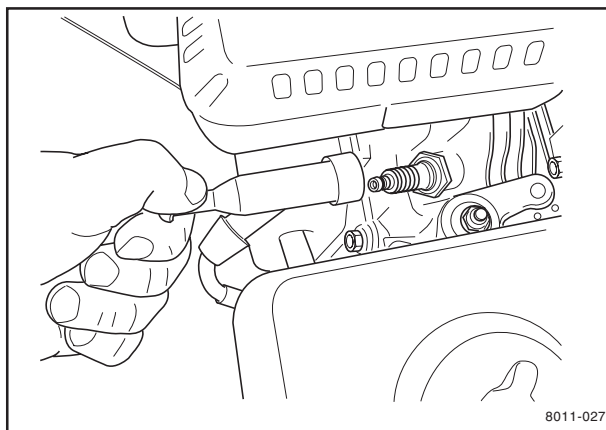

Disconnect the spark plug cable before repair work.



Reduce the risk of fire by keeping the machine clean.

PRESENTATION

Presentation

Congratulations on your choice of an exceptionally high quality product. This operator's manual describes the Husqvarna lawn aerator. The machine is available in two models: AR19 and AR25.

Both machines are equipped with a 4 hp Honda four-cycle engine.

AR19 is the smaller of the two machines (see illustration). It is recognizable for its collapsible handle.

AR25 is broader and has a fixed handle.

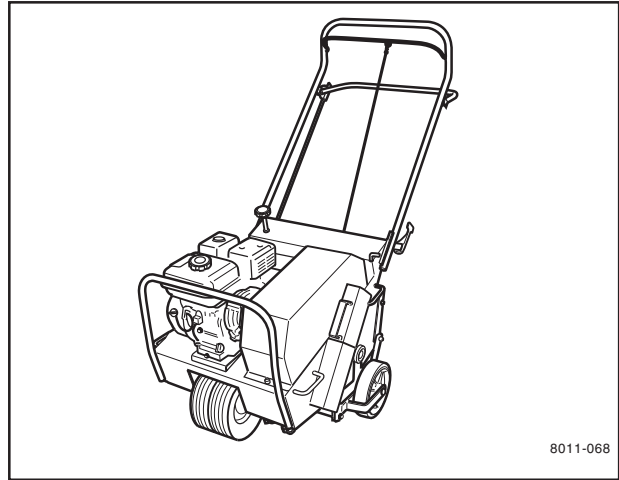

Main components and operating instruments

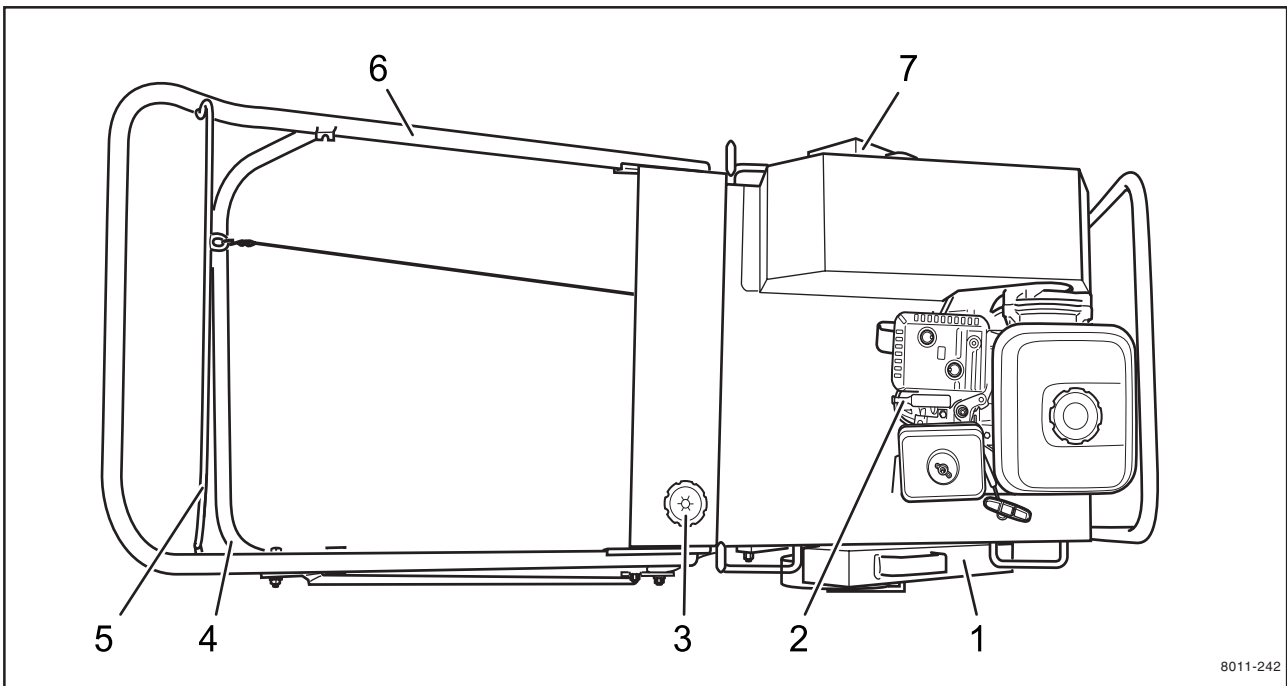

- | | |
|---|------------------|
| 1. Weight | 5. Clutch handle |
| 2. Engine with reduction gear | 6. Handle |
| 3. Adjustment knob for rear wheel depth/stability | 7. Weight |
| 4. Rear wheel control | |

PRESENTATION

Engine

Exterior engine components and operating instruments:

1. Throttle
2. Starter
3. Starter handle
4. Fuel valve
5. Choke control
6. Air filter
7. Spark plug
8. Muffler
11. Oil dipstick engine
12. Oil drainage engine
13. Oil level guard
14. Engine switch
15. Fuel tank
16. Fuel filler cap
21. Reduction gear
22. Oil refill gear
23. Oil level gear

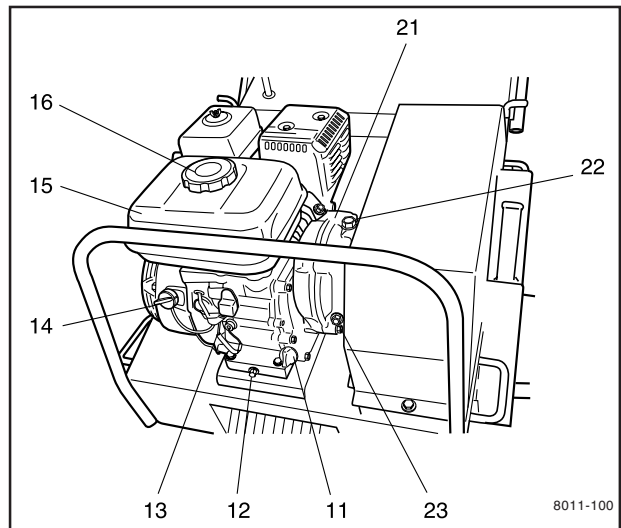
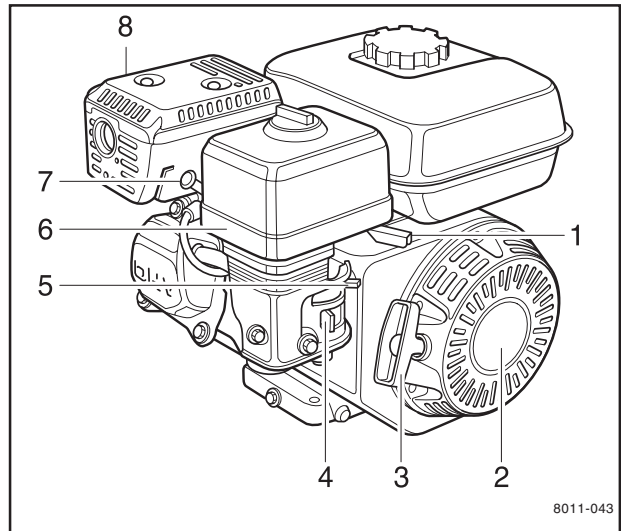

Throttle

The lever controls engine speed.

The image shows half throttle. Turning the lever to the left increases throttle and to the right decreases throttle.

Turning the lever completely to the right puts the engine at idle. If the engine stalls in idle, the idle speed can be adjusted; see the chapter "Maintenance/Idle adjustment".

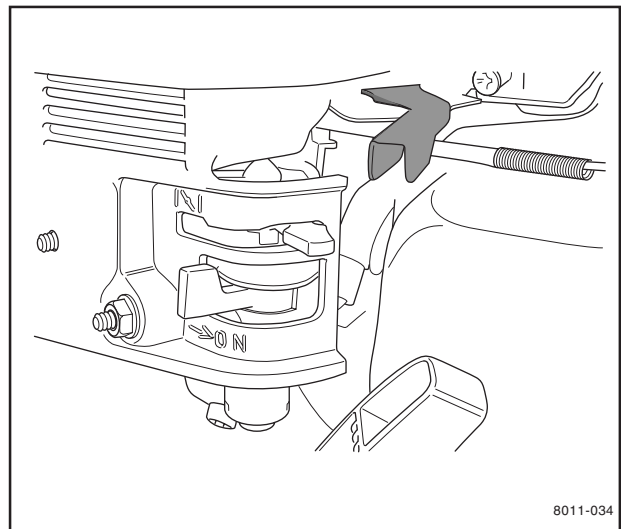

PRESENTATION

Starter

The starter is of the magnapull type with spring return. To replace the return spring or starter cord, contact an authorized service workshop.

Starter handle

Misuse of the starter handle can damage the starter. Never twist the starter cord around your hand. Pull out the handle slowly until the gears mesh. Do not pull out the starter cord completely and do not let go of the starter handle when extended.

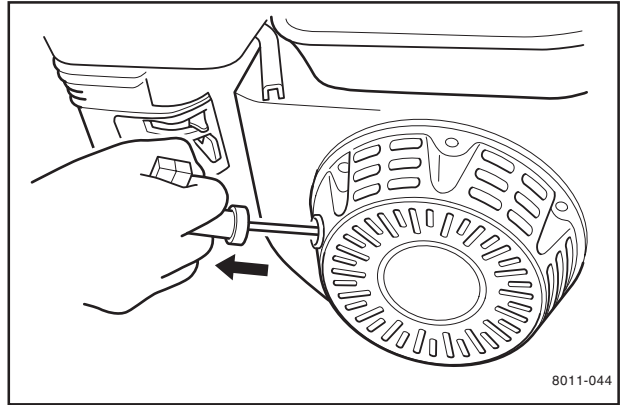

Fuel valve

The fuel valve opens and closes the connection between the tank and the carburetor.

The illustration shows the tank valve closed; to open, turn the lever completely to the right. There is no middle position.

Turn off the valve when the machine is not in use to avoid flooding the carburetor.

The fuel valve is combined with a sludge reservoir. For cleaning instructions see the chapter "Maintenance/Cleaning the sludge reservoir".

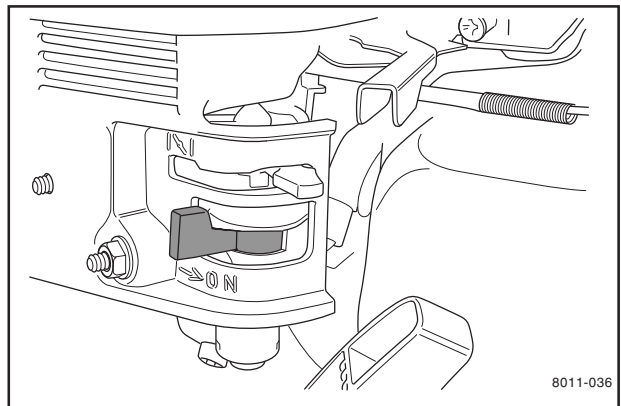

Choke control

The choke control opens and closes the choke valve in the carburetor. This is only used to start a cold engine.

The image shows the choke valve open; to close, turn the lever to the left. The midway positions can be used. When the engine starts, the lever can be turned gradually to the right as long as it continues to run smoothly. Forgetting the choke is evident as the engine runs roughly and produces black smoke. This also results in increased fuel consumption.

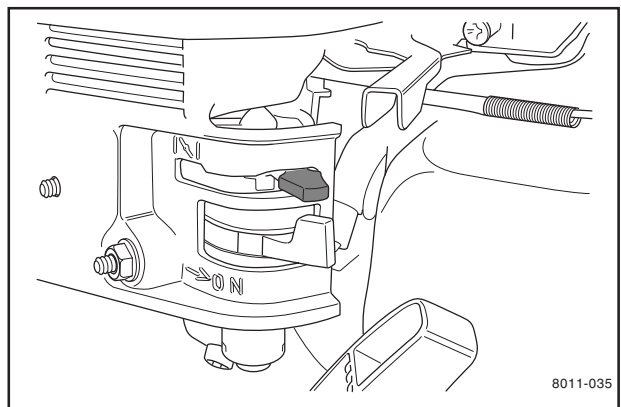

Air filter

The engine air filter is located under the cowling. It consists of a foam rubber pre-filter and a paper filter cartridge. See the chapter "Maintenance/Replacing the air filter" for cleaning instructions. Running the machine with a dirty air filter will cause the engine to run on partial choke and show the same symptoms as a forgotten choke described above. It can also be difficult to start.

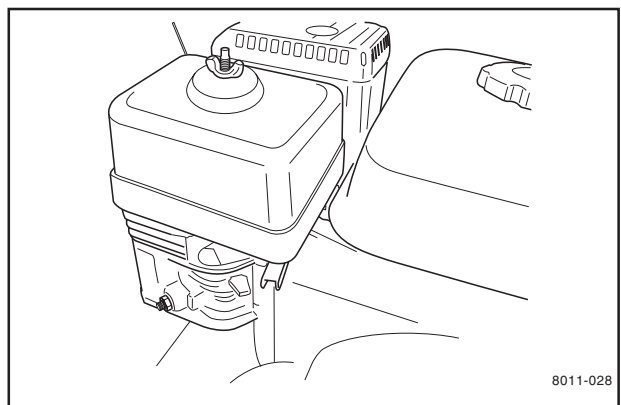

PRESENTATION

Spark plug

The engine spark plug is hidden under the ignition cable shoe. When performing service, it is important that the engine cannot start accidentally. For this reason, always remove the ignition cable shoe from the spark plug. To avoid pulling the cable, the cable shoe is equipped with a special handle; see the illustration.

Type of spark plug, see "Technical data".

Service instructions, see "Maintenance/Ignition system".

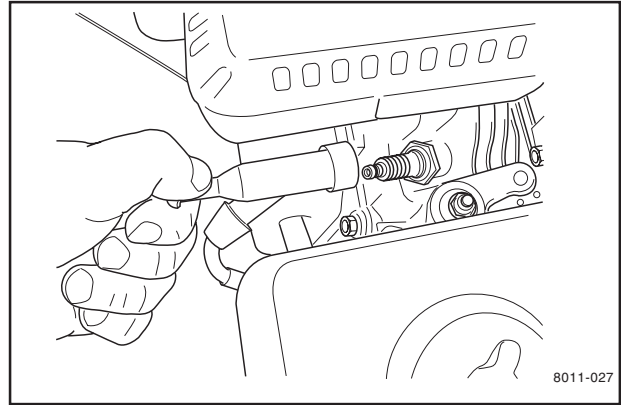

Muffler

The engine muffler is equipped with a heat protective cowling. Nonetheless, it still becomes hot when the engine is running. Avoid touching the muffler when it is warm. Risk for burns.

Oil dipstick

The dipstick for the crankcase oil reservoir is located on the front of the engine. Refill the engine oil in the hole where the dipstick fits. When checking the oil level, the dipstick should **not** be screwed in. The machine should be parked on even ground with the engine stopped. Never run the engine without the dipstick in place. Certain engines have electronic oil level guards. They stop the engine and prevent restarting if the level becomes too low. Yet you should not rely entirely on the level guard; rather you should check the oil using the dipstick.

For normal use, we recommend SAE 10W-30-weight engine oil service SF-SG; see also the chapter "Lubrication/Engine oil".

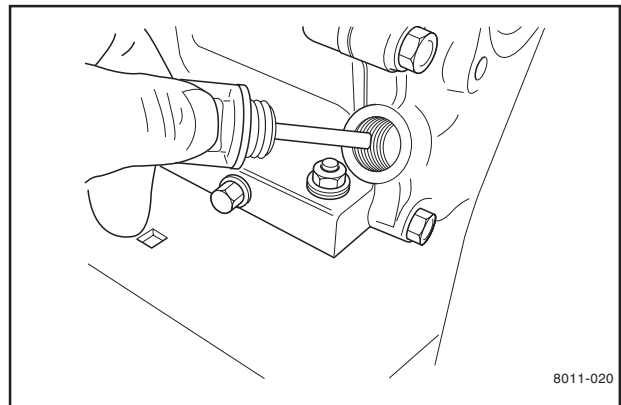

Oil drainage

The drainage screw for the crankcase oil reservoir is located on the front of the engine.

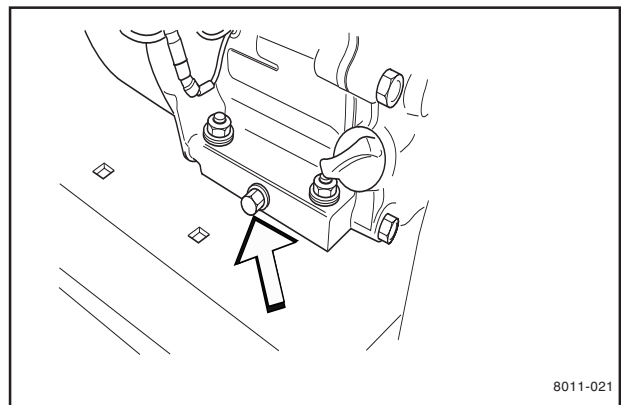

IMPORTANT INFORMATION

Used engine oil is a health hazard and legislation prohibits disposal on the ground or in nature; it should always be disposed of at a workshop or appropriate disposal location. Avoid skin contact; wash with soap and water in case of spills.

Engine switch

The engine switch stops the engine. The illustration shows the switch in the OFF position (short circuited electrical system). To start the engine, the switch must be first set to the ON position.

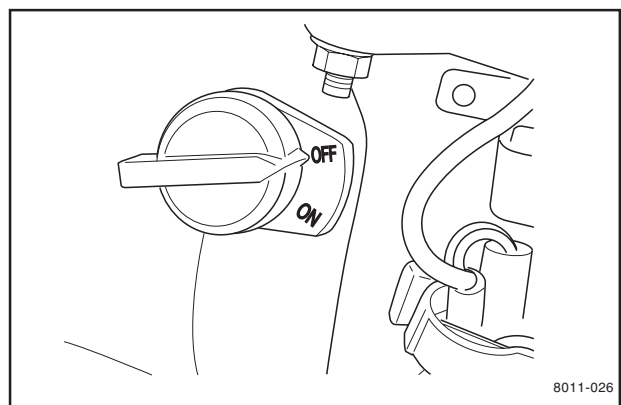

PRESENTATION

Fuel tank

Underneath the tank, there is a fuel filter combined with the fuel valve. The tank volume is 2.5 liters/ 0.66 US Gal.

Fueling

Read the safety instructions before fueling. Keep the fuel and fuel tank clean. Avoid filling the machine with dirty fuel. Make sure the fuel cap is properly tightened and the gasket is not damaged, particularly before washing the machine.

Use unleaded gasoline with minimum 86 octane rating. Never use gasoline mixed with two-cycle oil.

For ethanol and methanol fuel, the following applies:

Maximum allowable ethanol 10% (volume).

Maximum allowable methanol 5% (volume).

Maximum allowable MTBE (Methyl Tertiary Butyl Ether) 15% (volume).

If the engine "bolts" at normal load it can be damaged. Change the fuel. If this does not help, contact an authorized service workshop.

Do not fill the tank completely; leave space for the fuel to expand as it warms up.

Reduction gear 1:6

The gear is directly coupled to the engine. A V-belt pulley is located on the output axle with a key. The gear reduces the speed of the engine so that the output axle turns at 1/6 of the engine speed.

Oil refill reduction gear

The oil is filled through the plug (1) at the top of the gearbox until it flows out of the hole for the removed oil level plug (2). Use the same oil type as you used in the engine. The gearbox can be filled with 0.15 liters/0.2 US qt.

Oil level reduction gear

The plug (2) is used to check the oil level in the gearbox. When checking the level, the machine must be parked on level ground. The plug can then be removed and the oil should be level with the hole.

The hole is also used to drain the oil, but then the machine must be tipped forwards.

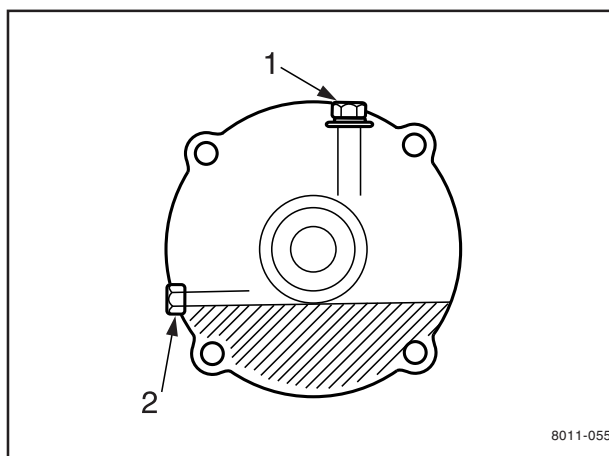
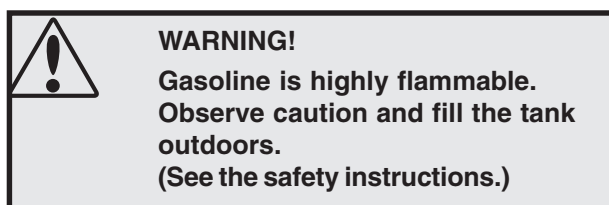
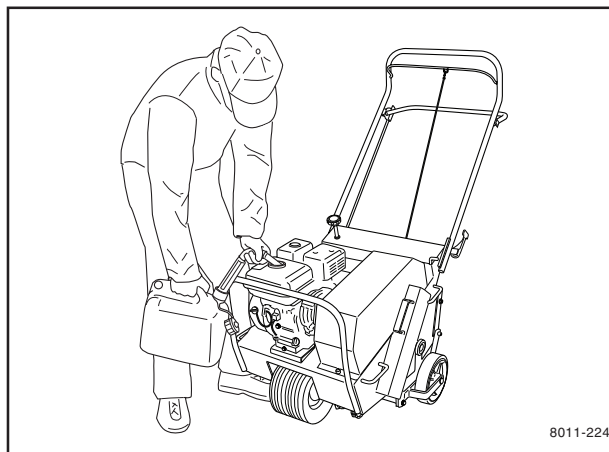

PRESENTATION

Controls on the handle

Rear wheel control

Pressing down the rear wheel control raises both rear wheels causing the tines to penetrate into the soil.

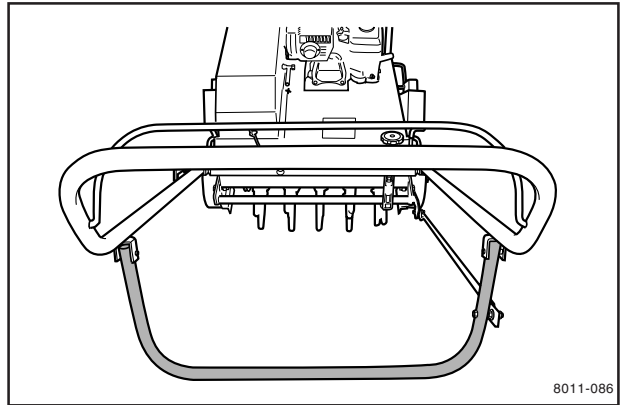

Clutch handle

Depressing the spring-loaded clutch handle towards you causes the machine to begin moving.

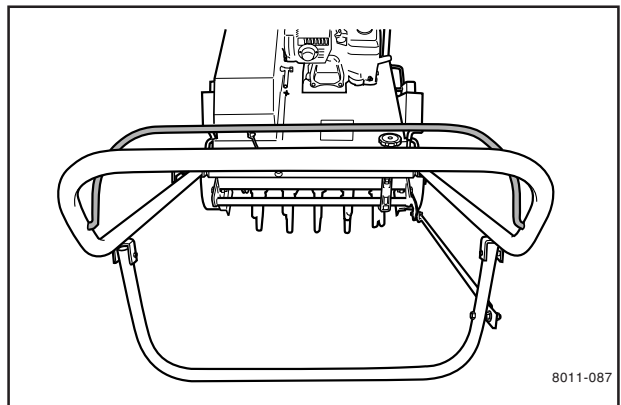

Cam lock for the handle

If the lever for the handle locking mechanism is opened outwards, the handle can be moved forwards to a locked position. For instructions on raising the handle, please see "Raising the handle".

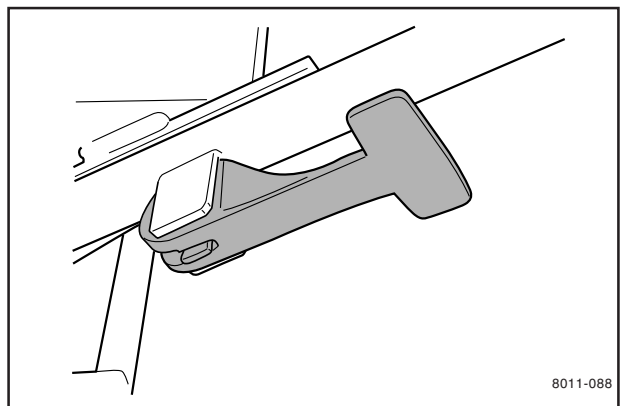

Raising the handle

First, lift the rear wheel control; then, the handle can be lifted into working position and locked in place with the cam lock.

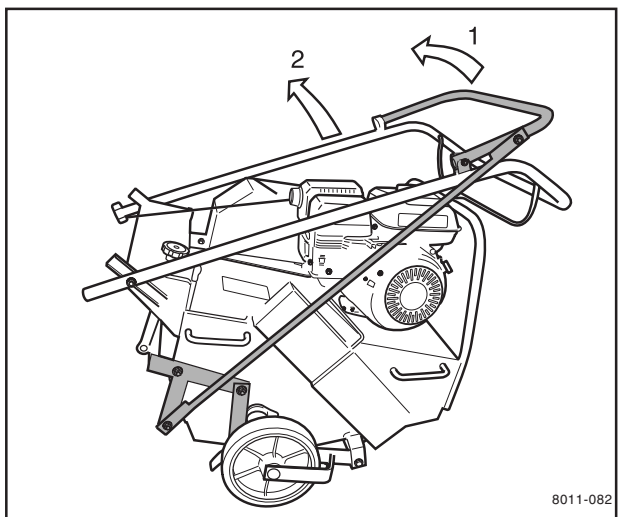

PRESENTATION

Adjusting the rear wheels

You can improve stability and maneuverability by turning the knob for the rear wheel depth/stability clockwise (see illustration). Turning the knob counterclockwise determines aeration depth in the following ways:

- (A) The rear wheels can be adjusted to the level of your choice so that you can control the penetration of the tines to a margin of a few millimeters. Aeration depth can be controlled accordingly.
- (B) With the rear wheels adjusted to the top position, you obtain maximum tine penetration. Pushing down on the machine's handle puts most of the weight of the machine on the tines. In this configuration, aeration depth will be greatest (the front wheel will rise).

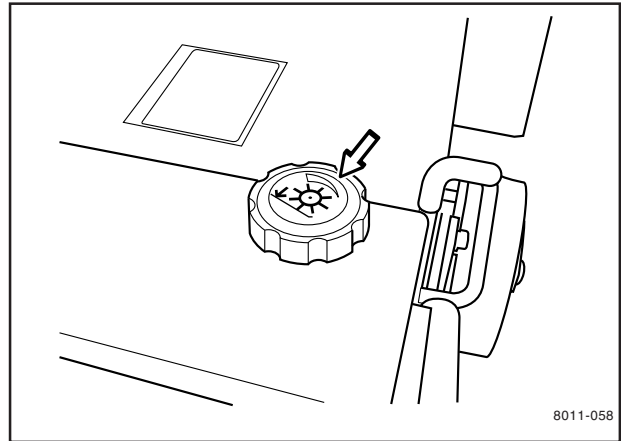

IMPORTANT INFORMATION

Adjusting for increased stability decreases the aeration depth. Lateral stability will increase (see "Running/Operating on hills"). Adjustments for greater stability will also improve maneuverability during aeration.

Weights

On each side of the machine there is a removable weight.

Depending on soil conditions, extra machine weight may be necessary for effective aeration. The weights are provided to give you added control and better tine penetration.

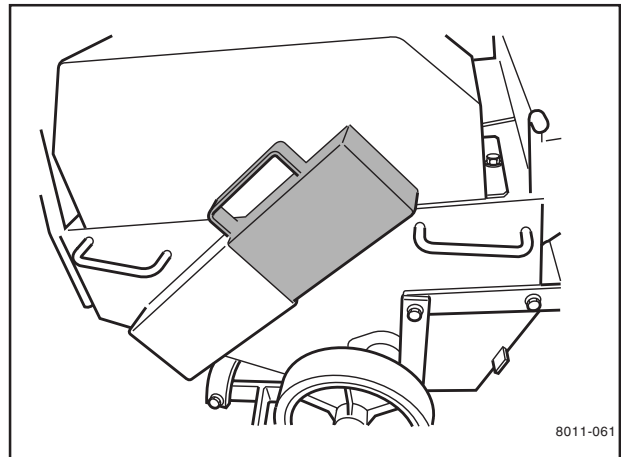

RUNNING

Starting the engine

Check that all daily maintenance as described in the maintenance schedule has been performed. Check that there is sufficient fuel in the tank.

Fuel valve

Open the fuel valve. Turn the lever all the way to the right.

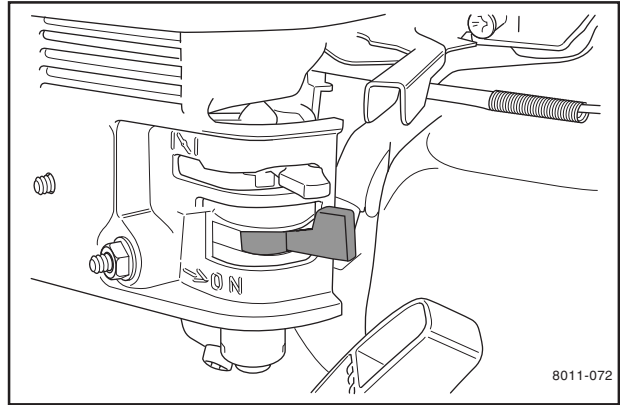

Choke control

When starting the engine warm, the lever should be in the right position; see the illustration.

When starting the engine cold or partially warm, turn the lever completely or partly to the left.

Move the lever back to the right once the engine starts. When the engine is cold, it may be best to move the lever back in several stages. Find the position where the engine runs smoothly.

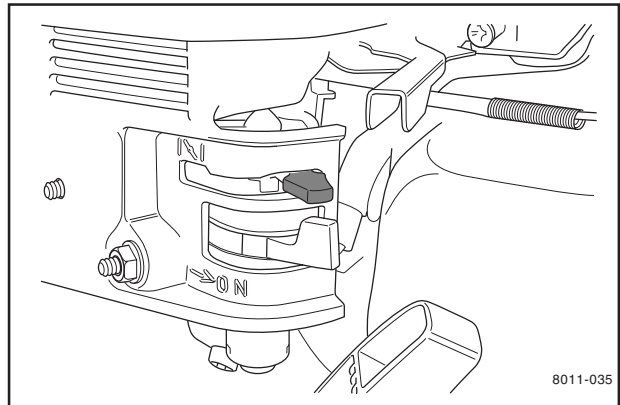

Engine switch

Turn the engine switch clockwise to ON.

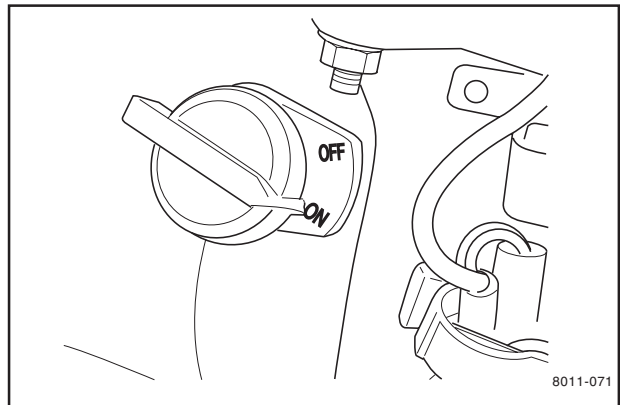

Starter handle

Misuse of the starter handle can damage the starter. Never twist the starter cord around your hand. Pull out the handle slowly until the gears mesh. Then give a sharp pull on the starter handle. Do not pull out the starter cord completely and do not let go of the starter handle when extended.

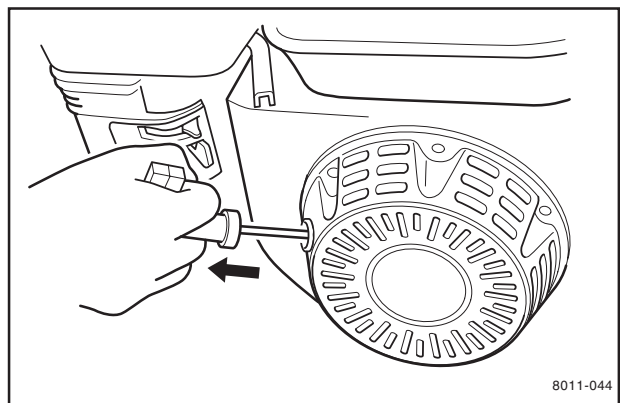

RUNNING

Throttle

Adjust the engine speed with the throttle. Moving the lever to the left increases throttle and to the right decreases throttle.

For machines with a throttle on the handle, the throttle on the engine should be set at idle position.

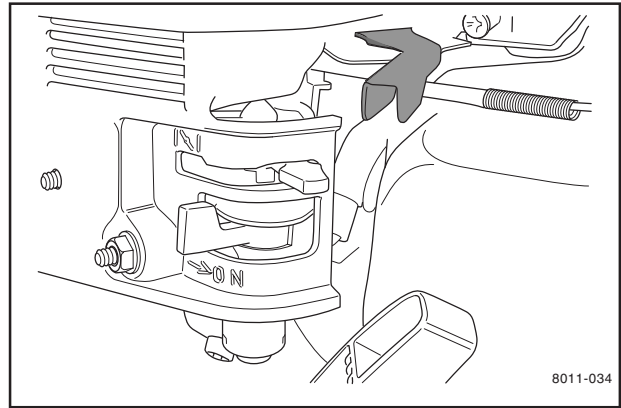

Cutting the engine

If the engine has been running full out, let it run easily for about 30 seconds to 1 minute at low speed.

Engine switch

Turn the engine switch counterclockwise to OFF.

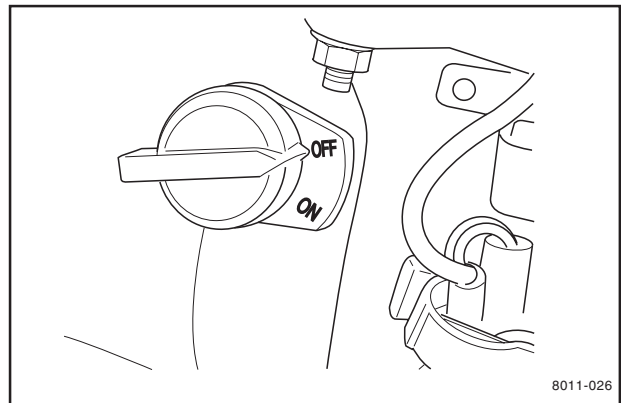

Fuel valve

Close the fuel valve. Turn the lever all the way to the left (see illustration).

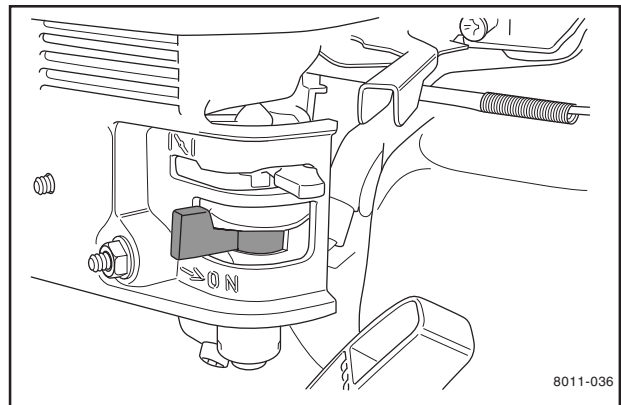

RUNNING

Aeration tips

Should I water the lawn before aeration?

Aeration is best performed on soft and moist ground. If you are unsure of soil conditions, e.g. in high clay content soil, a simple test can be used to determine whether you need to water before aerating. Press a garden spade or a large screwdriver into the soil. You should be able to reach about 5 – 7.5 cm with little effort. If you are unable to do so, you must water the lawn one day before aerating.

When should I use the removable weights?

The soil conditions dictate whether extra machine weight will be required for effective aeration. The weights are provided to give you added control and better tine penetration.

Before you start

1. Make sure that the collapsible handle is in working position and locked in place with the cam lock (applies to model AR19).
2. Fit the weights if necessary.
3. Make sure that the clutch handle releases properly and that the clutch cable slides easily. (applies to model AR19).
4. Make sure that the throttle/clutch releases properly and that the throttle and clutch cables slide easily (applies to model AR25).

Aeration

1. Start the engine and adjust the throttle so that you can move at a comfortable walking pace and maintain control over the equipment at all times.
2. Set the desired depth using the depth knob (see illustration). Aeration depth decreases if you turn the knob clockwise.
3. Lower the tines into the soil by pressing down the rear wheel control (the rear wheels rise).
4. Press down the handle. This allows the tines to penetrate better and makes the machine easier to steer (the front wheel rises).
5. Depress the clutch handle towards the handle and the machine will begin moving.
6. Stop by releasing the clutch handle.
7. Adjust the throttle setting on the engine as necessary to achieve a comfortable speed.

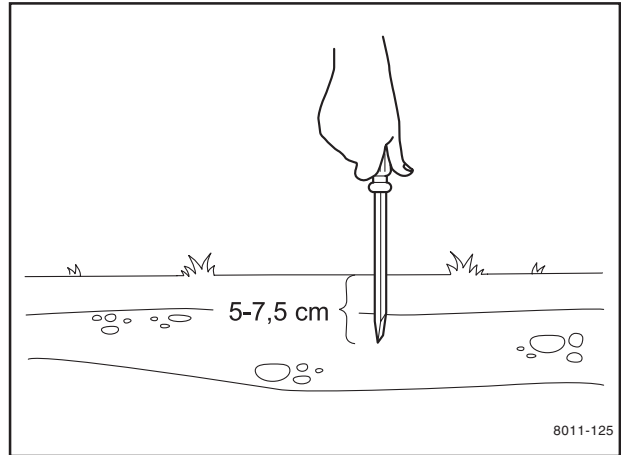

IMPORTANT INFORMATION

**Clear the lawn of any extraneous objects.
Clearly mark rocks and other fixed objects.
Be especially sure to check for hidden electrical cables or similar in the surface of the lawn.**

IMPORTANT INFORMATION

By lifting the rear wheels all the way (for maximum aeration depth) you reduce the machine's stability but increase aeration depth.

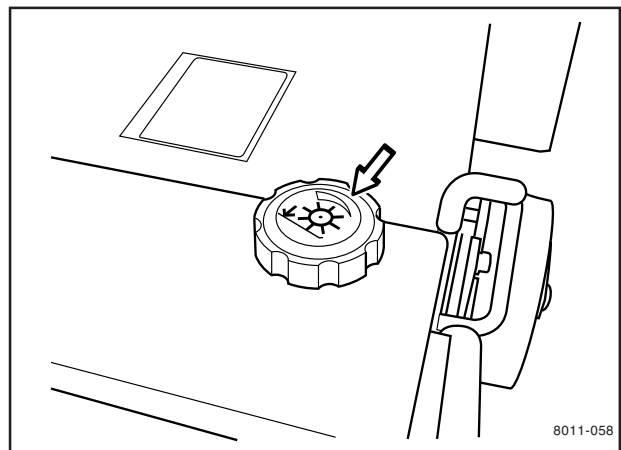

RUNNING

Turning and maneuvering the lawn aerator

You maneuver the machine by gradually controlling the direction with the handle while operating the lawn aerator. We recommend setting engine speed so that you can move at a comfortable walking pace. This also helps you maintain complete control when working in tight spaces.

When the machine is set for increased stability (with lowered rear wheels and reduced tine penetration), it is easier to turn.

If you want to back or make sharp turns, you can use one of two methods. Choose the one that is safest and easiest for the prevailing circumstances:

- Release the clutch, lift the rear wheel control and turn the machine on the rear wheels.
- Release the clutch, lift the handle and turn.

Operating on hills

The machine is not intended for use on steep slopes. Be careful when the angle of the lawn aerator causes the center of gravity of the machine to move to the downhill side of the machine. In such cases you may find the following:

- It is more difficult to steer the machine and maintain its balance.
- The tine penetration will become uneven when you run the machine across the slope of the hill. Because the center of gravity changes, the tines on the downhill side of the machine will penetrate deeper than the uphill tines.

When using the machine on hills, you should remember the following:

- It is better to run the machine up and down the hill rather than crosswise.
- Set the machine for increased stability using the rear wheel depth/stability knob. This can be particularly beneficial if you decide to run the lawn aerator across a hill. Another advantage with using the rear wheel depth setting when aerating across a hill is more consistent aeration depth for the uphill tines relative to the downhill tines.
- Removing the weight from the downhill side of the machine when running across a hill reduces rollover risk and maintains consistent aeration depth.
- Move the weight over to the uphill side when changing direction across a hill.

IMPORTANT INFORMATION

Never run over hard objects or surfaces (walkways, driveways, paved surfaces, etc.) with the tines down.



WARNING!

Do not use the machine on grades of more than 20°.

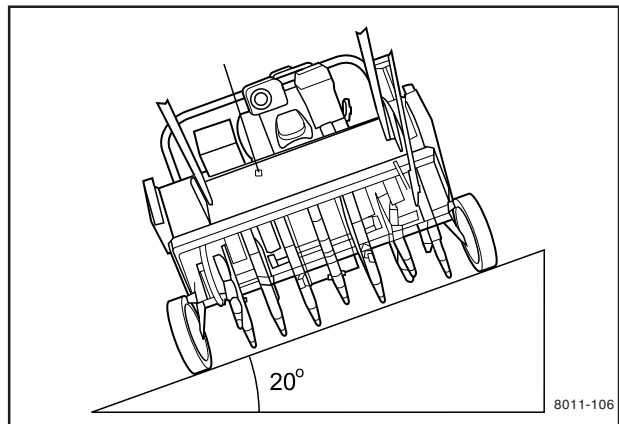

WARNING!

In extreme cases (very steep slopes), the machine may become so imbalanced that it is at risk of tipping.



WARNING!

Never raise the tines from the ground when running the machine up or down hills. Only raise them on level ground.

MAINTENANCE

Maintenance schedule

The following is a list of maintenance procedures that must be performed on the machine. For those points not described in this manual, visit an authorized service workshop.

Maintenance	Page	Daily maint. before starting	Maintenance interval months/hours			
			1/25	3/50	6/100	12/300
Check the engine oil level	40	●				
Replace engine oil ¹⁾	39				●	
Check gearbox oil level	40		●			
Replace gearbox oil ¹⁾	40					●
Check the air filter	25	●				
Clean the air filter ²⁾	25			●		
Replace air filter cartridge ²⁾	25					●
Clean sludge reservoir for fuel system	26				●	
Check and clean the spark plug	28				●	
Replace the spark plug	28					●
Check idle speed	26					●
Check and adjust play in valves ⁴⁾	-					○
Clean fuel tank ⁴⁾	-					○
Check, replace fuel lines as necessary ^{4, 5)}	-					○
Check clutch and clutch cable	29	●				
Check chain tension	36	●				
Check wear and tension on the belts	30	●				
Check tine wear and condition	35	●				
Check the chassis, nuts and bolts, sprockets and set screws	-	○				
Check the throttle cable (model AR25)	27	●				
Lubricate the rear wheels	41			●		
Lubricate the chain ^{2, 3)}	41		●			
Lubricate the links ^{2, 3)}	41		●			
Lubricate cam lock for the handle	42		●			
Other lubrication; see the Lubrication schedule						

¹⁾ First change after 20 hours. ²⁾ In dusty conditions maintenance is required at shorter intervals. ³⁾ With daily use, the machine shall be lubricated twice weekly. ⁴⁾ Performed by authorized service workshop. ⁵⁾ Performed every second year.

● = Described in this manual.

○ = Not described in this manual.



WARNING!

No service operations may be performed on the engine or unit unless:

- The engine is stopped.
- The ignition cable has been removed from the spark plug.
- The machine is securely parked where it will not tip or begin rolling.

MAINTENANCE

Replacing the air filter

If the engine seems weak, produces black smoke or runs unevenly, the air filter may be clogged. For this reason, it is important to clean and replace the air filter regularly (see the maintenance schedule for the proper service interval).



WARNING!

Allow the exhaust system to cool before performing service. Risk for burns.

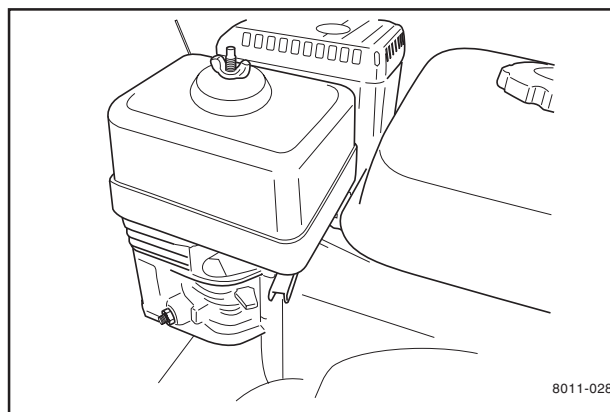

8011-028

Cleaning/replacement of the air filter is carried out as follows:

1. Undo the wing nut and lift off the air filter cowl.
2. Remove the foam rubber pre-filter and clean using a mild detergent.

Squeeze it dry with a clean cloth.

Soak it with new engine oil. Wind the filter in an absorbent cloth and squeeze out excess oil.

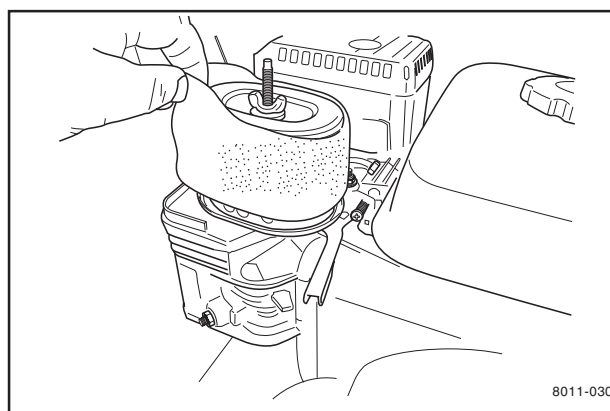

8011-030

3. Remove the wing nut in the air filter and remove the paper filter. Tap the paper filter against a fixed surface to remove dust. If the paper filter is still dirty or damaged, it must be replaced.

IMPORTANT INFORMATION

Do not use compressed air over 2 bar/ 30 PSI to clean the paper filter.

Do not wash the paper filter.

Do not oil the paper filter.

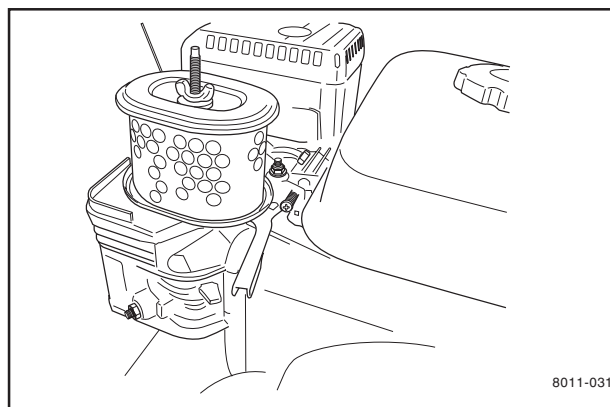

8011-031

4. Refit the air filter as follows:
 - Mount the paper filter in the air filter housing and tighten using the wing nut.
 - Refit the pre-filter on the paper filter.
 - Return the cowl to the air filter housing and tighten using the wing nut.

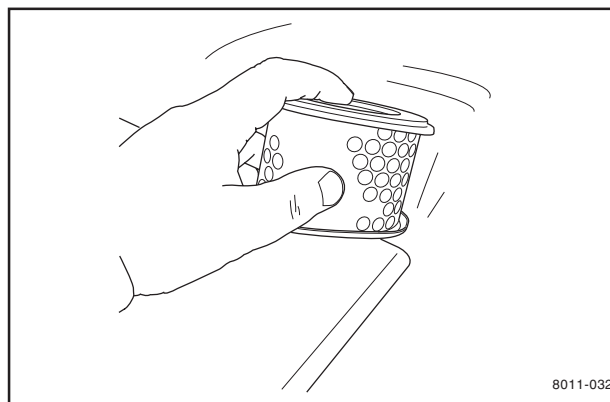

8011-032

MAINTENANCE

Cleaning the sludge reservoir

1. Close the fuel valve.
2. Unscrew the sludge reservoir (2). Make sure not to misplace the o-ring (1).
3. Clean the reservoir and the o-ring in e.g. white spirit and dry carefully.
4. Put the o-ring in place in its track and replace the sludge reservoir. Tighten it moderately to avoid damaging the threads.
5. Turn the fuel valve to ON and check for leaks. If it leaks, replace the o-ring.

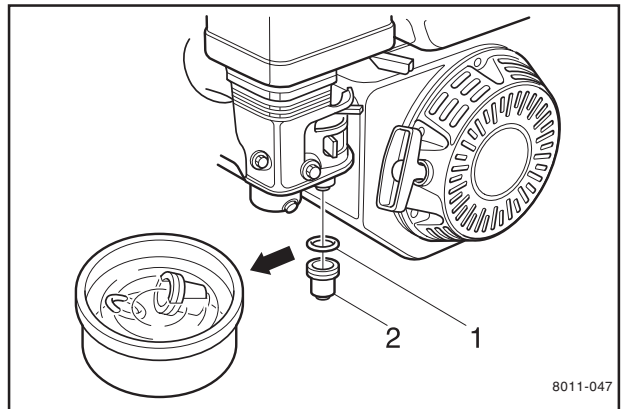
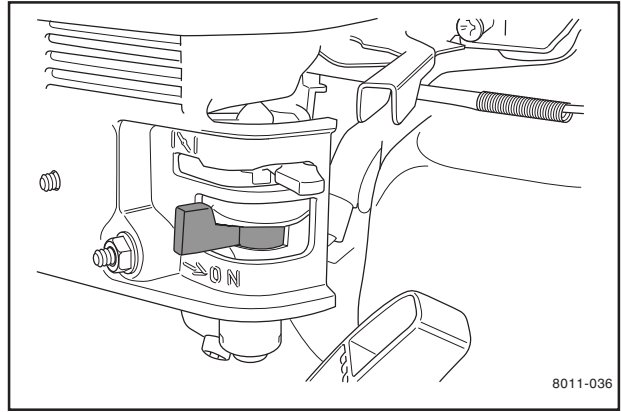

Idle adjustment



WARNING!
Risk for carbon monoxide poisoning.
Perform the adjustment outdoors.

1. Start the engine and run it until it reaches normal working temperature.
2. Adjust the throttle to idle position or so that the engine runs at the lowest possible speed.
3. Turn the idle screw (1) so that the engine idles at 1250-1400 RPM.
4. Increase the idle speed with the throttle and move it right back to idle position. Check engine speed again.

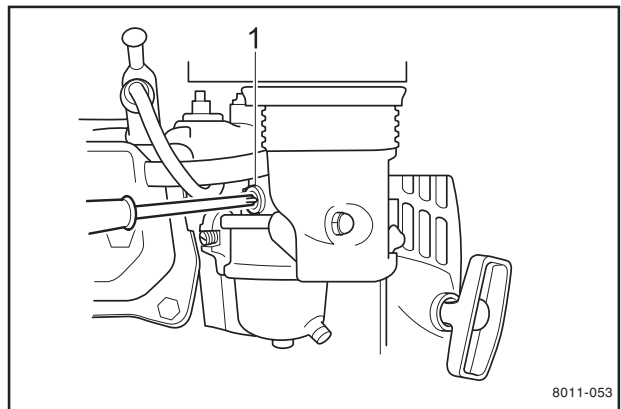

MAINTENANCE

Adjusting the throttle cable

Only applies to model AR25.

1. Start the engine and allow it to reach operating temperature.
2. Adjust the throttle cable at the adjustable mounting (the left in the illustration) by turning the adjustment nut. The tighter the setting, the higher the engine speed. Undoing the nut reduces engine speed.

IMPORTANT INFORMATION

If the throttle is properly adjusted, engine speed increases somewhat when the clutch is released.

- If the clutch is released too early, the engine stalls.
- If engine speed is too high, you lose your ability to start moving gradually and under control.

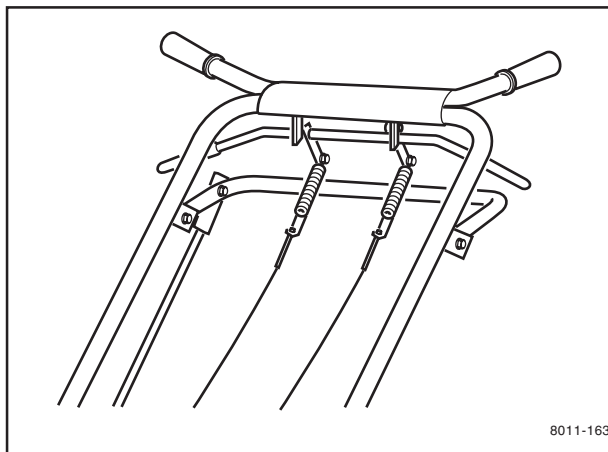

Replacing the throttle cable

Only applies to model AR25.

1. Measure the length of the cable that extends past the cable screw before disconnecting the cable.
2. Remove the old throttle cable and insert a new one through the guide hole on the back of the cowling.
3. Insert the new cable through the cable screw the same distance as the old one (see step 1) and tighten the screw. This measurement is only approximate and may require adjustment. See the section above "Adjusting the throttle cable" to adjust the throttle settings.
4. Fit the new adjustable mounting (see the lower illustration) on the spring on the throttle/clutch.

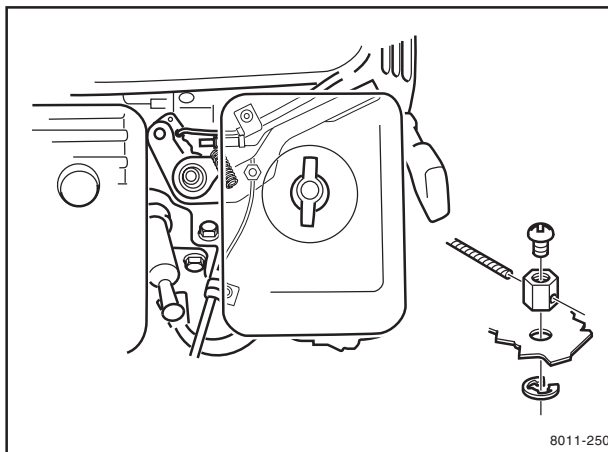

IMPORTANT INFORMATION

As the cable length increases between the cable screw and the adjustment nut, the engine speed decreases. If engine speed is too low, the engine will stall when the clutch is released. As the cable length decreases between the cable screw and the adjustment nut, the engine speed increases. If engine speed is too high, you lose your ability to start moving under control.

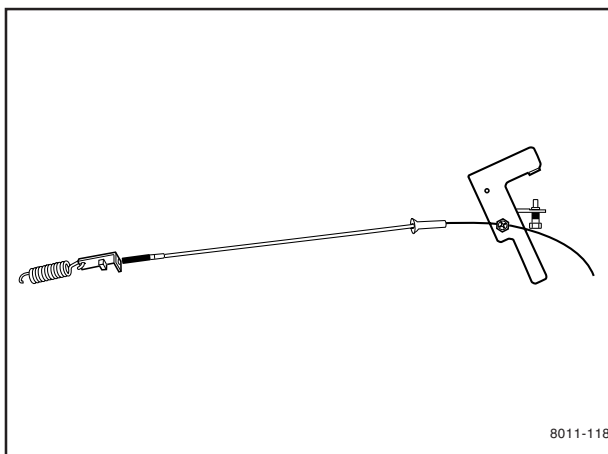

MAINTENANCE

Ignition system

The engine is equipped with an electronic ignition system. Only the spark plug requires maintenance.

For recommended spark plug, see "Technical data".

IMPORTANT INFORMATION

Fitting the wrong spark plug type can damage the engine.

1. Remove the ignition cable shoe and clean around the spark plug.
2. Remove the spark plug with a 13/16" (21 mm) spark plug socket wrench.
3. Check the spark plug. Replace the spark plug if the electrodes are burned or if the insulation is cracked or damaged. Clean the spark plug with a steel brush if it is to be reused.
4. Measure the electrode gap with a gapping tool. The gap should be 0.7–0.8 mm/0.028–0.031". Adjust as necessary by bending the side electrode.
5. Reinsert the spark plug, turning by hand to avoid damaging the threads.

IMPORTANT INFORMATION

Inadequately tightened spark plugs can cause overheating and damage the engine. Tightening the spark plug too much can damage the threads in the cylinder head.

6. After the spark plug is seated, tighten it using a spark plug wrench so that the washer is compressed. A used spark plug should be turned 1/8–1/4 of a turn from the seated position. A new spark plug should be turned 1/2 a turn from the seated position.
7. Replace the ignition cable shoe.

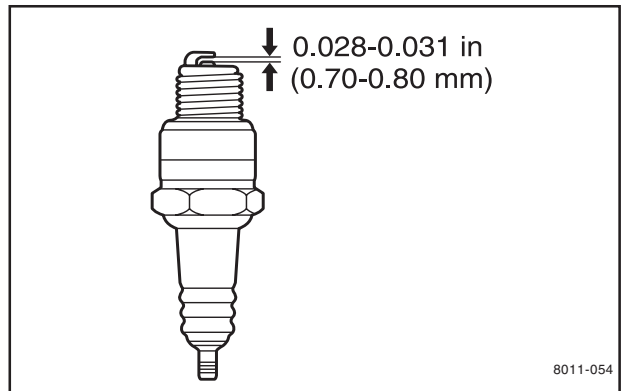
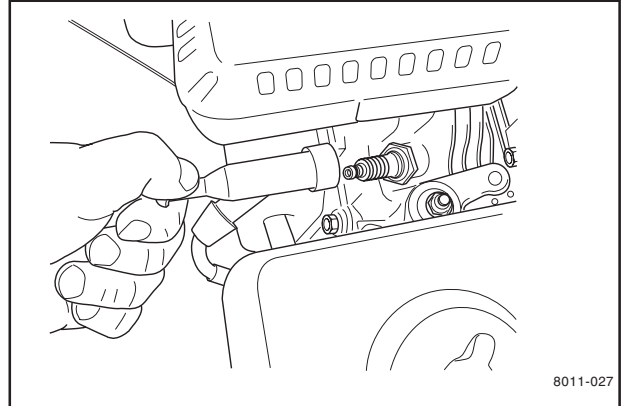

MAINTENANCE

Replacing the engine

1. Remove the weights to improve access.
2. Remove the drive guard cover (1).
3. Remove the drive belt.
4. Remove the four engine screws (2). Two on each side.
5. Remove the engine from the unit.

IMPORTANT INFORMATION

Lawn aerators of model AR25 have two pairs of shim plates under the engine.

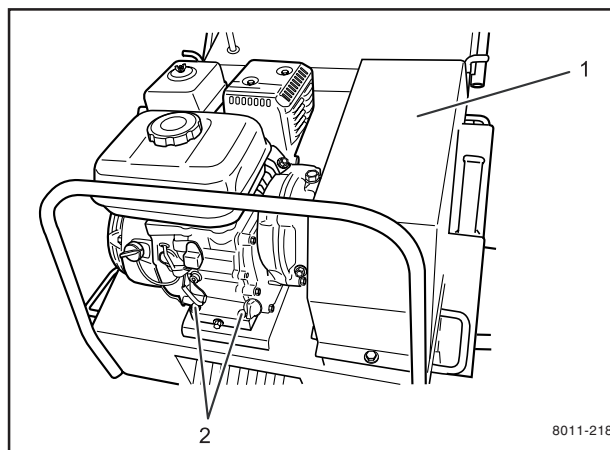

8011-218

6. Undo the hex screws, remove them and make sure not to lose the pulley (3) and the key (4).
7. Refit the components per the instructions above (but in reverse order).
8. Adjust the drive belt and align the pulley (see chapter "Maintenance/Replacing and aligning the drive belt").

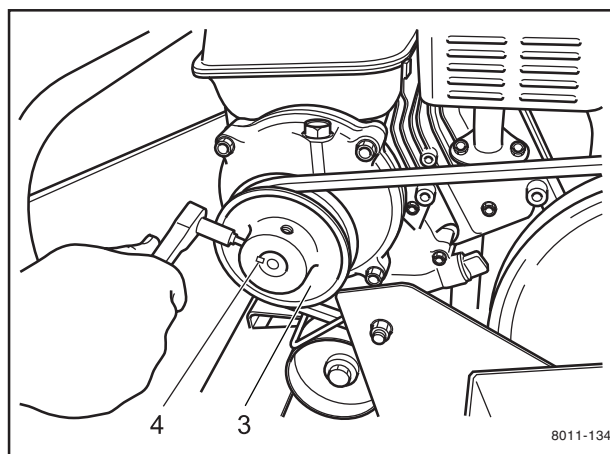

8011-134

Replacing the clutch cable

1. Turn off the engine and remove the old clutch cable.
2. Insert the new cable through the hole in the rear of the cowl.
3. Attach the lower end of the clutch cable to the mounting on the tensioning pulley spring (see illustration) and the upper end to the s-hook on the clutch handle.
4. Adjust the cable length using the nut so that the clutch spring stretches 19.1–31.2 mm when the clutch handle is depressed.

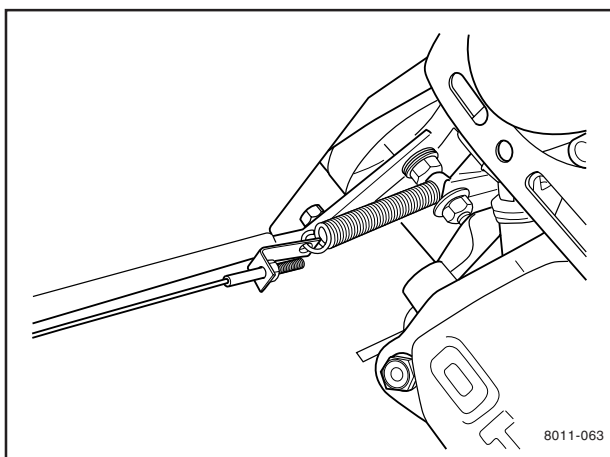

8011-063

MAINTENANCE

Replacing and adjusting the drive belt

1. Turn off the engine and remove the drive guard cover.
2. Remove the drive belt (1).
3. Check for wear on the pulleys and replace as necessary.
4. Check the alignment of the pulleys by making sure that they are in line with one another and with the tensioning pulley (2). If not, correct the alignment.

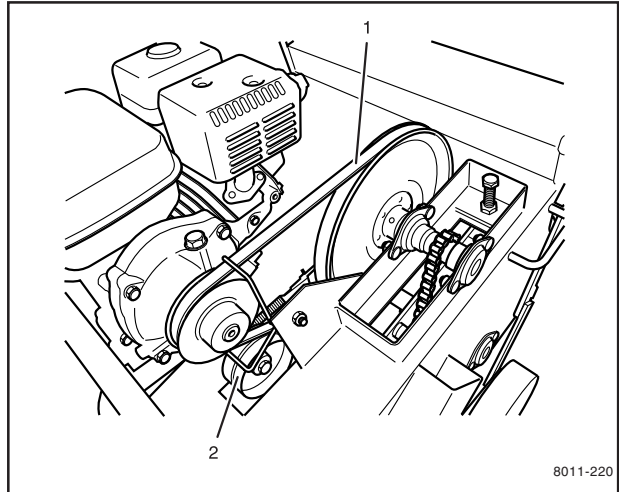

5. Fit a new drive belt by first pulling it over the smaller pulley and then over the larger pulley (see illustration).

IMPORTANT INFORMATION

Many components, including the drive belt on your Husqvarna lawn aerator, are specially manufactured for Husqvarna to maximize durability for many hours of use. Replace all components using Husqvarna original spare parts for maximum performance and lifespan.

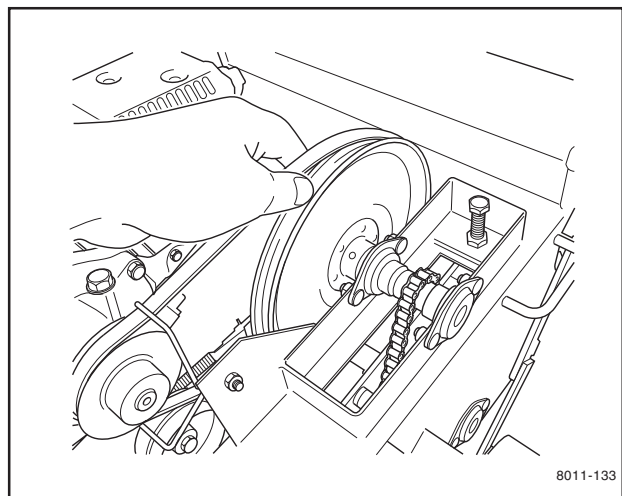

6. Make sure that the drive belt is seated in both pulleys (1).
7. Make sure that the drive belt does not fasten in the upper belt guide when the tensioning pulley is tightened. Check that the lawn aerator rolls freely (with the handle collapsed on model AR19) when the drive belt is slack. Adjust the belt guide and the clutch cable length as necessary.
8. For instructions on clutch adjustment, see chapter "Maintenance/Replacing the clutch cable".
9. Refit the drive guard cover.

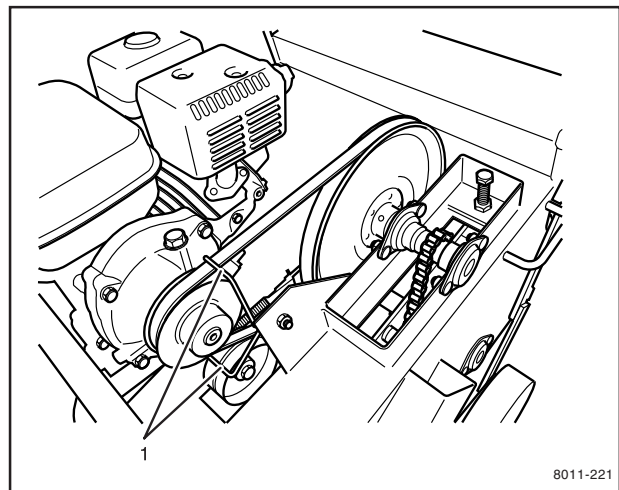

MAINTENANCE

Cam lock for the handle

Only applies to model AR19.

1. The cam lock (3) on the handle should lock if you press it with moderate force using your hand. The frame of handle (2) should be properly affixed to the machine.
2. Check the locking nut on the cam rod (1). If the nut is easy to turn by hand when the cam is released, it will no longer properly affix the handle and must be replaced for the lock to continue functioning safely.

Adjustment

Put the handle in working position and slowly tighten the locking nuts on the cam rod (1/4 turn at a time) until the cam lock functions with moderate manual pressure.

IMPORTANT INFORMATION

Excessive adjustment of the locking nut can damage the cam rod. Always replace nuts that become easy to turn so that the handle does not come loose. For the cam mechanism to operate easily, the edge of the cam should be lubricated with a small amount of grease.

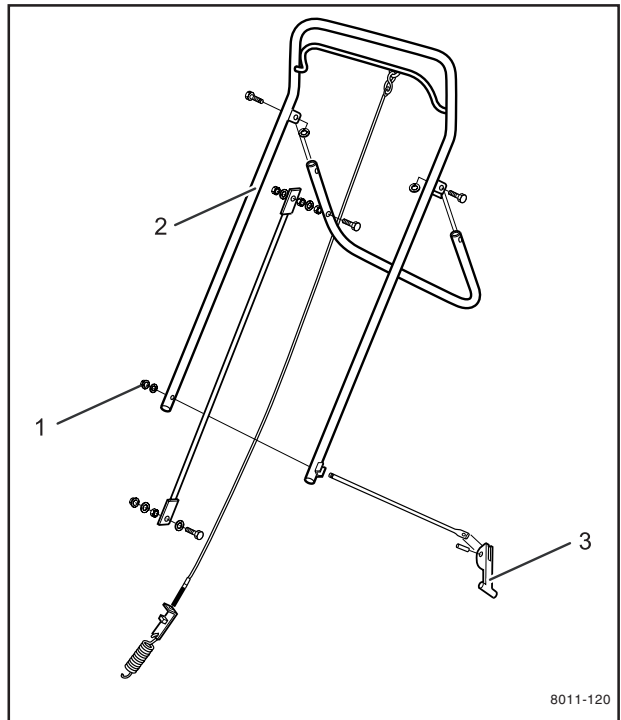

MAINTENANCE

Wheels

Replacing the drive wheel axle

1. Turn off the engine and empty all fuel from the fuel tank.
2. Remove the weights and the drive guard cover.
3. Remove the locking nut (2) on the idler adjustment screw (1) to slacken the chain. Remove the master link and the chain.
4. Tip the lawn aerator backwards so that it is resting on the handle. The front wheel ends up about 30 cm above the ground.



WARNING!

Secure the handle so that the lawn aerator cannot tip over.

5. Remove the nuts (1) and screws (2) (4 of each on model AR19 and 6 on model AR 25) for the wheel axle bearings.
6. Remove the wheel axle with wheels and sprocket. Model AR19 does not have the complete bearing closest to the sprocket; the illustration shows model AR25.
7. Undo 2 setscrews (hex screws) for the sprocket (5) and pull the sprocket and the bearings from the axle. To remove the bearings (3), you must first remove the locking collar (4). Undo the setscrew, insert a punch into the hole beside the setscrew and tap it with a hammer so that the locking collar turns opposite the wheel's normal rotation direction. If the bearings have rusted in place, they must be replaced together with the wheels and axle.
8. Fit the bearings and sprocket loosely on the axle. For model AR19, the hub side of the bearing should be turned away from the wheel. Model AR25 has three bearings. On both of the bearings closest to the wheel, the hub should be turned away from the wheel. On the bearing closest to the sprocket, the hub should be turned away from the sprocket.
9. Tighten the bearings in place.
10. Center the wheel in the wheel opening in the cowling (see illustration). Set the locking collars by tightening the setscrews.
11. Align the sprocket with the other sprockets and tighten both of the setscrews (hex screws) for the sprocket. Use blue Loctite when the key is in place.
12. To fit the chain, follow instructions in chapter "Maintenance/Replacing the chain".
13. Adjust the chain (see chapter "Maintenance/Adjusting chain tension") and refit the drive guard cover.

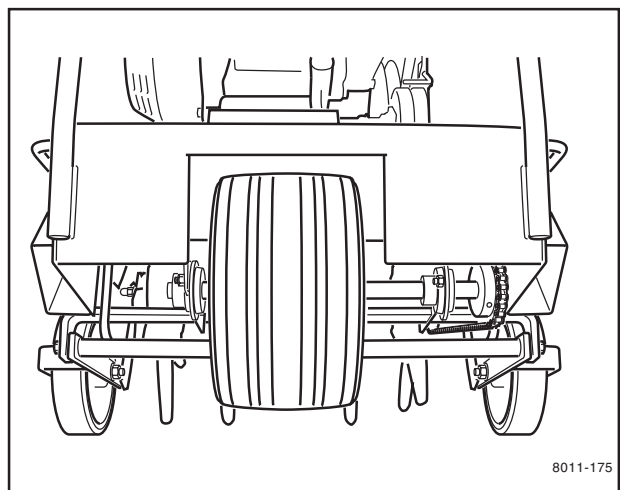
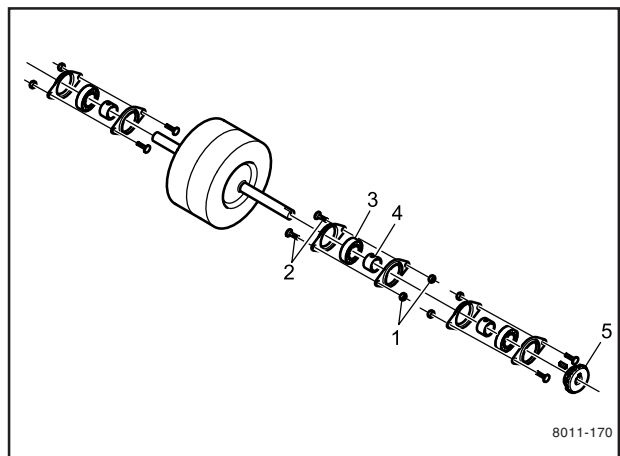
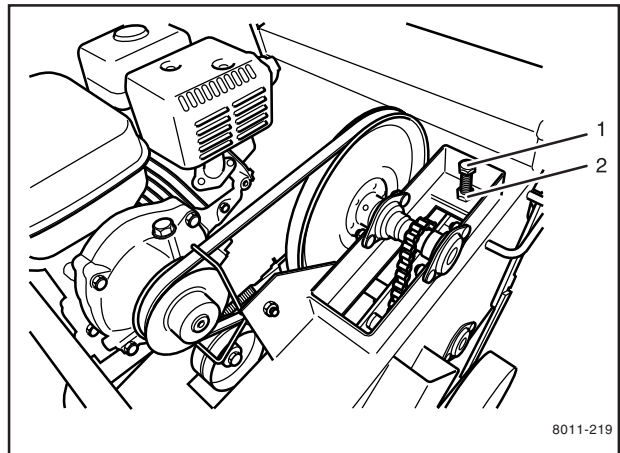

MAINTENANCE

Replacing the rear wheels

Applies to model AR19.

1. Make sure the machine is parked on level ground and that the engine is off.
2. Lower the rear wheel control so that the lawn aerator is resting on the tines.
3. Turn the depth adjustment knob for rear wheel depth/stability clockwise so that the rear wheels are set at minimum depth (= increased stability).
4. Remove the axle nut and washer. Pull out the axle bolt and remove the wheel from the wheel carriage.
5. Install the new wheel with the grease nipple turned outwards and the seals carefully in place on the wheel bushing. Insert the axle bolt through the wheel and the wheel carriage. Fit the washer and nut and tighten firmly.
6. Grease the wheel bearings.

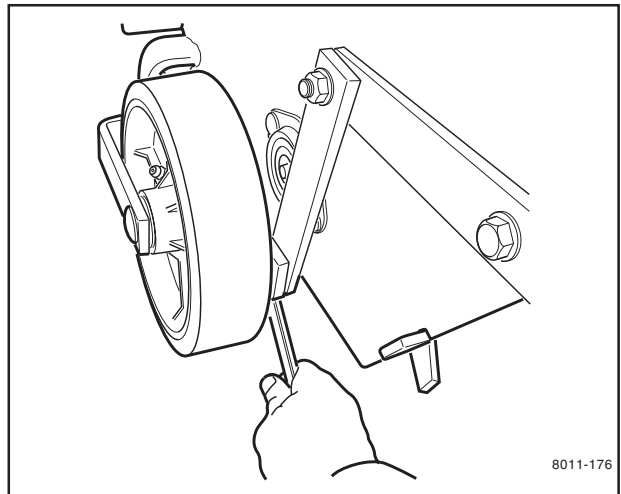

Applies to model AR25.

1. Make sure the machine is parked on level ground and that the engine is off.
2. Lower the rear wheel control so that the lawn aerator is resting on the tines.
3. Turn the depth adjustment knob for rear wheel depth/stability clockwise so that the rear wheels are set at minimum depth and increased stability.
4. Remove the hairpin cotter pin (1).
5. Remove the wheel and axle assembly from the machine (2).
6. Refit the hairpin cotter in the axle to prevent loss.

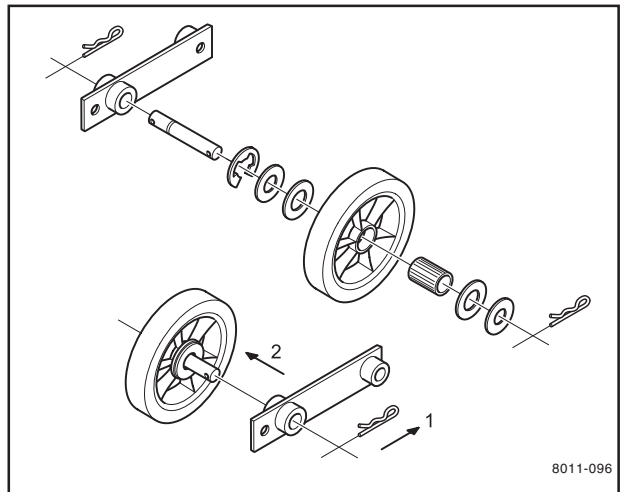

MAINTENANCE

Tines and tine shaft

Replacing the tines

1. Turn off the engine and remove the weights.
2. Collapse the handle (applies to model AR19).
3. Note the direction of the tine screw.
4. Remove and replace the tines by undoing the appropriate stop screw (1). Remove the setscrew (2) and the tine. Fit a new tine in the same direction and affix it using the setscrew. Once the tines have been replaced, tighten the stop screws.

IMPORTANT INFORMATION

Replace worn nuts so that the screws will keep the tines in place.

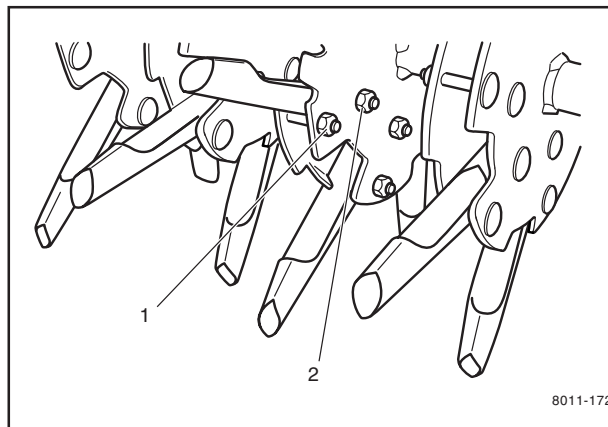

Replacing the tine shaft bearings

1. Turn off the engine and remove the weights.
2. Remove the drive guard cover.
3. Collapse the handle for better access to the tines (applies to model AR19).
4. Lift the machine about 10 cm. Chock the rear wheels and insert blocks.
5. Turn the drive chain manually for access to the master link.
6. Slack the chain by turning the idler adjustment screw counterclockwise.
7. Remove the master link and free the chain from the rotor sprocket.
8. Remove the nuts (1) and screws (2 per bearing) that hold the outer bearings of the tine rotor shaft in the side panels of the machine (see illustration).
9. Remove the tine rotor shaft.
10. Remove the tine shaft bearings by undoing the setscrew on each locking collar. Insert a punch into the hole beside the setscrew and tap it with a hammer so that the locking collar turns opposite the normal rotation direction (see illustration, principle).
11. Reassemble the machine by following the instructions above in the reverse order.
12. For instructions on chain replacement and chain tension adjustment, see chapter "Maintenance/ Replacing the chain" and "Maintenance/ Adjusting chain tension".

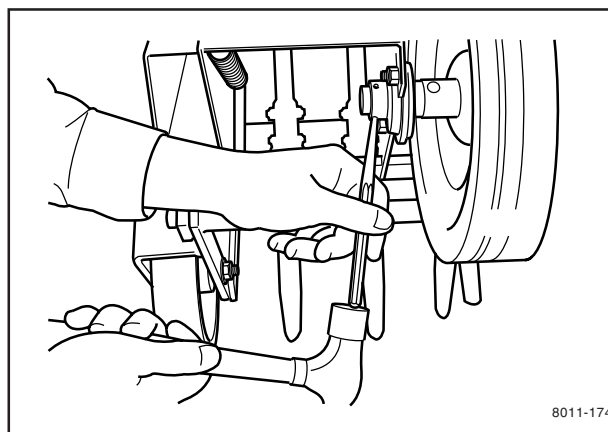
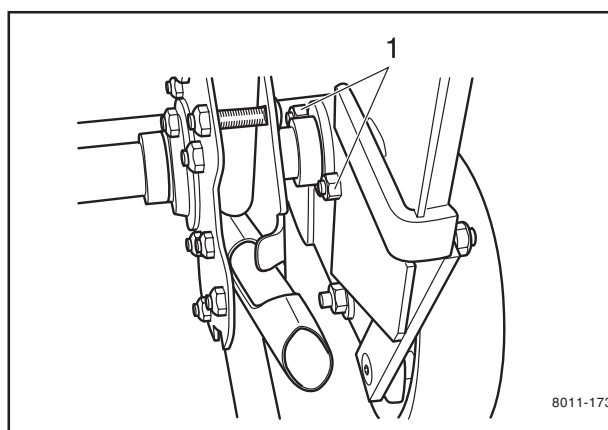

MAINTENANCE

Replacing the freewheeling tine assembly

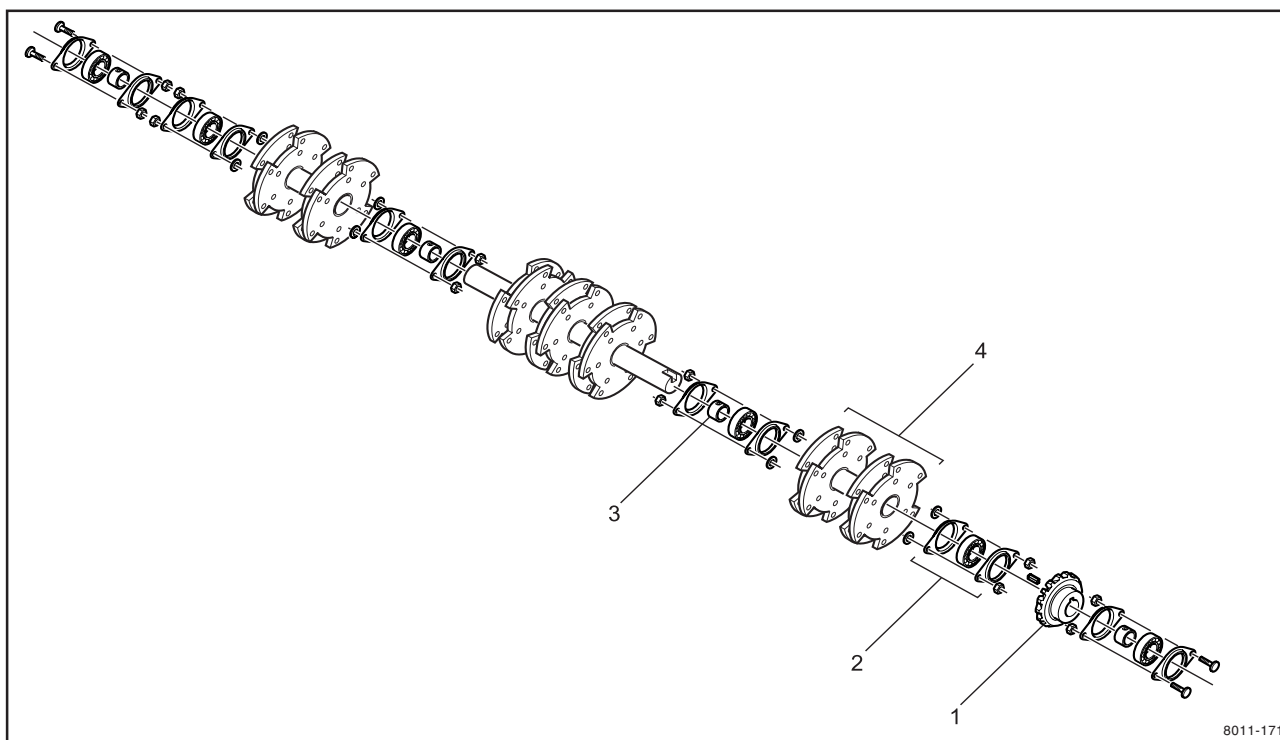

Model AR19 has one freewheeling tine assembly at each side but model AR25 has two. The illustration above shows model AR25.

Perform steps 1 through 10 in the previous section "Replacing the tine shaft bearings" and then the following:

1. Remove the sprocket (1) by undoing the two setscrews (when removing one side's freewheeling tine assembly).
2. Remove the bearing (2) on the outside of the freewheeling tine assembly from the rotor and undo the locking collar (3) inside the inner bearing. To free the locking collar, you must first remove the setscrew and then insert a punch into the hole beside the setscrew and tap it with a hammer so that the locking collar turns opposite the normal rotation direction.
3. Remove the freewheeling tine assembly (4).
4. Place the new rotor assembly beside the old assembly so you can see which direction the new tines are to be fit. You can also refer to the tines on the fixed-tine assembly as an example of proper assembly.
5. The inner bearing shall be installed with the bearing hub facing the fixed tines. Make sure that the inner bearing has a locking collar.
6. Once the new tines have been installed on the rotor, you should mount the new freewheeling tine assembly and the outer bearing. The bearing hub should face the fixed tines. The bearing with the locking collar faces the fixed tines and butts up against the shoulder of the shaft. Tighten the bearing nuts by hand.
7. Tighten the four bearing nuts properly.
8. Lock the bearing collar with a hammer and punch. Make sure that the collar locks in the same direction as the rotation of the rotor.
9. Refit the outer shaft bearing and the rotor assembly per instructions in steps 1 through 10 in the section "Replacing the tine shaft bearings" (but in reverse order).

Tine wear

After your Husqvarna lawn aerator has been used for some time, the tines will become worn out. When this happens, their aeration performance will diminish. Check the tines using the drawing and replace them before they are worn beyond their minimum length. New tines are 12.7 cm long.

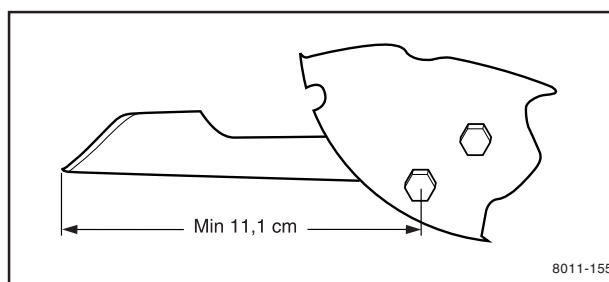

MAINTENANCE

Chain

Replacing the chain

1. Turn off the engine.
2. Remove the drive belt cover (see illustration).
3. Undo the chain's idler adjustment screw (1) and lock nut (2).
4. Remove the master link and the chain.
5. Check and align the sprockets as necessary. The sprocket at the front wheel (4) (see lower illustration) and the sprocket on the tine shaft each have two hex screws.
6. Install the new chain from the top and link the ends just behind the front sprocket (4).

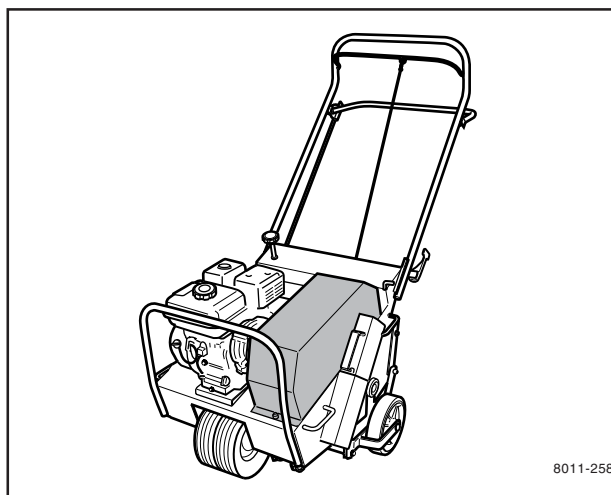

IMPORTANT INFORMATION

It is easiest to connect the chain just behind the front sprocket.

7. Fit the master link with the clip set on the engine side of the chain with the opening towards the front of the machine.
8. Adjust the chain tension; see "Adjusting chain tension" below.

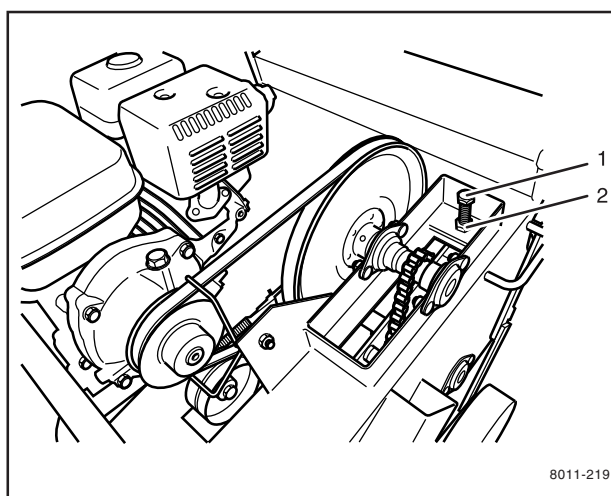

Adjusting chain tension

1. Turn off the engine.
2. Remove the drive guard cover and undo the locking nut (2) on the idler adjustment screw (1).
3. Turn the idler adjustment screw and adjust the chain tension to give 3.2 mm to 6.4 mm play at the midway point between the sprocket (4) and the rotor sprocket on the tine shaft assembly. See the illustration for the dimension (3).
4. Tighten the locking nut (2).

IMPORTANT INFORMATION

Husqvarna recommends replacing the sprockets at the same time as the drive chain.

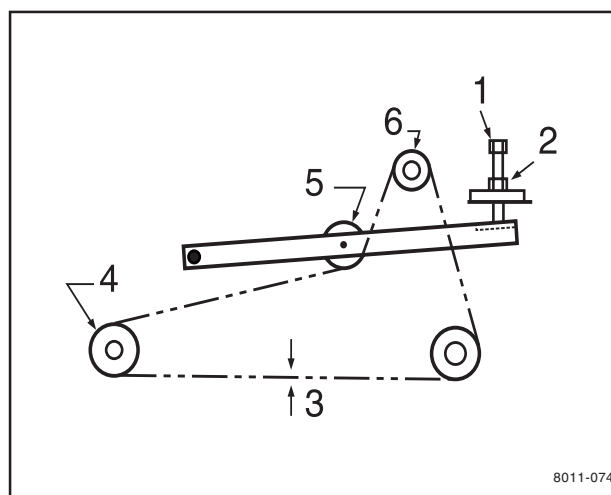

MAINTENANCE

Cleaning and washing

Regular cleaning, washing and lubrication will increase the machine's lifespan. Make it a habit to clean the machine directly after use, before the dirt sticks.

Check before rinsing that the fuel tank lid is properly in place to avoid getting water in the tank.

Use caution when using high-pressure spray because warning decals, instruction signs, bearings, the chain and the engine can be damaged. **Do not exceed 70 bar/1000 PSI water pressure when cleaning.**

Lubricate the machine after cleaning. This is particularly important if the machine is to be stored.



Two minute rule

The machine may be tipped forward to facilitate access for cleaning or service, but **no longer than 2 minutes**.

If the machine is held in this position for too long, the engine can be damaged by gasoline draining into the crankcase. Should this happen, perform an extra oil change on the engine. Remove the spark plug and turn the engine over a few revolutions with the starter handle before starting the engine again.

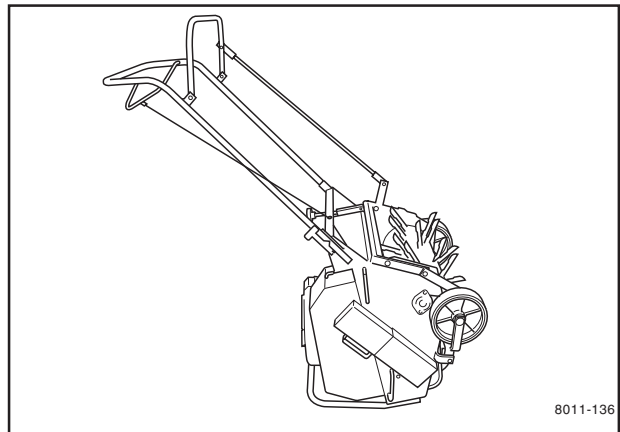

LUBRICATION

Lubrication schedule

12/12	1/12	1/52	1/365	AR19, AR25		25h	50h	100h	300h
			👁️	1		1		👇	
(👇)	👁️			2		2	👁️		👇
	🚰			3		3	🚰		
	🔧			4		4		🔧	
	🚰			5		5			
	🚰			6		6	🚰		
		🔧		7		7			
	🔧			8		8	🔧		
		🚰		9		9			

8011-280

LUBRICATION

General

Stop the engine and remove the ignition cable before attempting to lubricate the machine.

Unless otherwise specified, when lubricating with grease use Husqvarna's Universal Grease no. 5310038-01 or Husqvarna's Lubrication Grease UL 21 no. 5310060-74.

Wipe away excess grease after lubrication.

It is important to avoid getting lubricant on the belt or the drive surfaces on the belt pulleys. Should this happen, attempt to clean them with spirits. If the belt continues to slip after cleaning, it must be replaced.

1. Engine oil

The engine should be warm (but not hot) when changing the oil. Warm oil flows out faster and leaves a smaller quantity of old oil inside the engine.

1. Place a suitable vessel underneath the oil drainage screw. Remove the oil dipstick (1) and the oil drainage screw (4).

Tip: Make a channel using a piece of cardboard to lead the oil directly into the vessel and avoid soiling the machine chassis.

2. Allow the engine oil to drain into the vessel; then replace the drainage screw. Tighten it moderately.

IMPORTANT INFORMATION

Used engine oil is a health hazard and legislation prohibits disposal on the ground or in nature; it should always be disposed of at a workshop or appropriate disposal location. Avoid skin contact; wash with soap and water in case of spills.

3. Make sure the machine is parked on even ground. Fill the new oil using the appropriate viscosity according to the diagram, API Service SF-SG, to the upper level mark on the dipstick = threads on the oil dipstick. The engine takes 0.6 liters/0.63 US qt of oil. When checking the oil level, the dipstick should **not** be screwed in.
4. Check that the rubber gasket is in position and screw the dipstick back into place. Do not tighten it askew or too hard or you may damage the threads.
5. Wipe up any spilled oil.

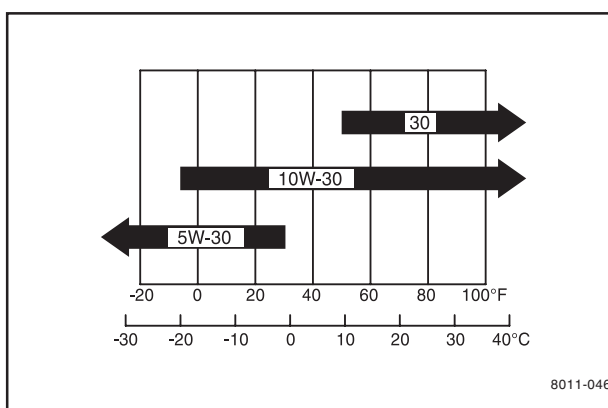
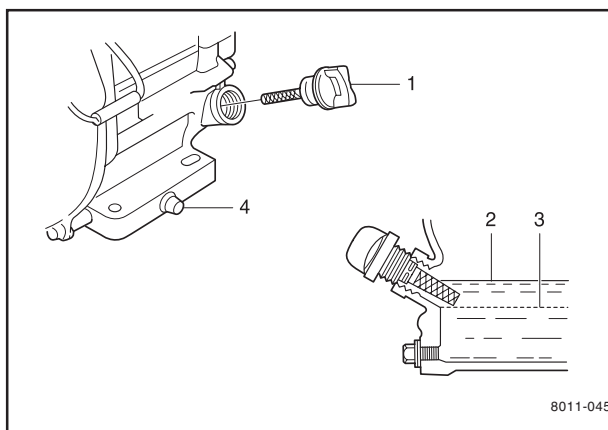
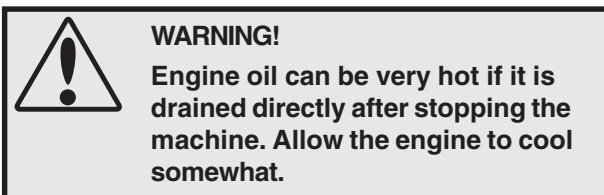

LUBRICATION

Checking the engine's oil level.

Make sure that the machine is parked on even ground with the engine stopped when checking the oil level.

1. Unscrew the dipstick and wipe it using paper towel or a lint-free rag.
2. Replace the dipstick without screwing it in. Remove and check the level on the dipstick.
3. Fill oil as necessary to the lip of the dipstick hole. Oil type, see chapter "Lubrication/1. Engine oil".
4. Check that the rubber gasket is in position and screw the dipstick back into place. Do not tighten it askew or too hard or you may damage the threads.

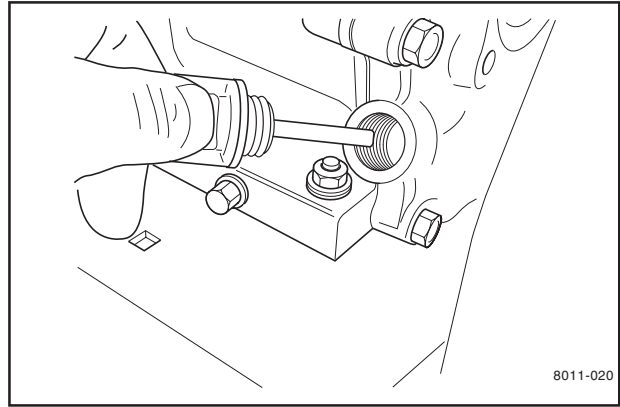

2. Oil change in reduction gear 1:6

The engine's reduction axle does not have a drainage screw, but the oil can be drained through the level plug hole (2) by tipping the machine forward. Because it is difficult to avoid spilling gasoline and releasing gasoline fumes, the oil should not be changed indoors.

1. Empty the fuel tank or put a vessel in place to collect gasoline spills.
2. Tip the machine forwards, place a vessel under the level plug (2) and remove the filler plug (1) and the level plug (2)
3. Allow the engine oil to drain into the vessel, right the machine and park it on even ground.
4. Refill using new oil of the same type as that in the engine in the filler hole until it runs over from the level plug. Volume 0.15 liters.
5. Replace the level and filler plugs. Tighten them moderately.
6. Wipe up any spilled oil.

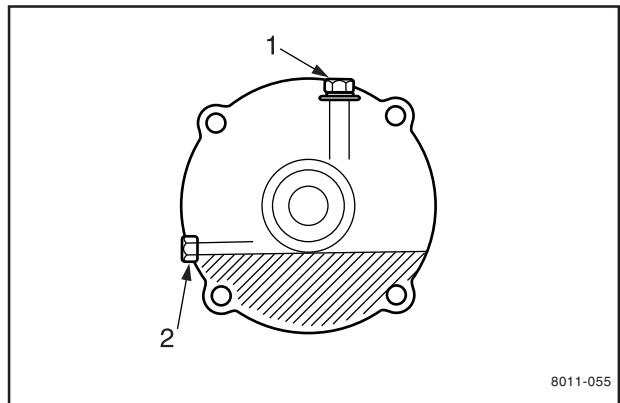

IMPORTANT INFORMATION

Used engine oil is a health hazard and legislation prohibits disposal on the ground or in nature; it should always be disposed of at a workshop or appropriate disposal location. Avoid skin contact; wash with soap and water in case of spills.

Checking the gearbox oil level

Make sure the machine is parked on even ground and that the engine is not running. Carefully remove the level plug (2) and check that oil drains out. If there is no oil leakage, the machine can be carefully tipped forward to estimate the oil level. If necessary, fill the oil in the filler plug hole (1) until it runs over from the level plug.

Replace the level and filler plugs. Tighten moderately.

LUBRICATION

3. Chain

Lubricate the chain so that it travels easily without binding. It is easiest to access with the drive guard cover dismantled. Use 30W engine oil or chainsaw oil or chain spray for motorcycles.

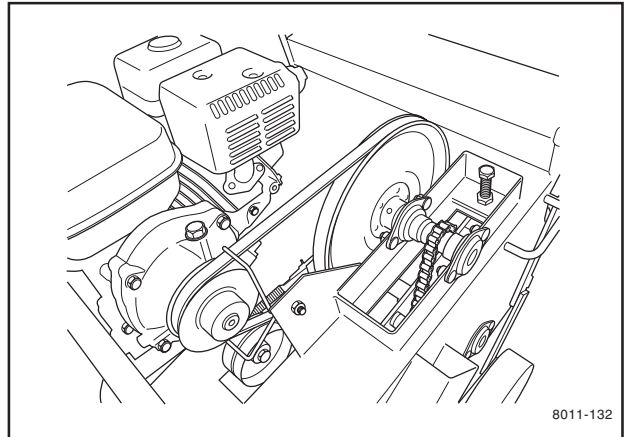

4. Rear wheels

Applies to model AR19.

Lubricate both rear wheels with a grease gun in the single nipple on the outside of the rear wheels until the grease begins to squeeze out.

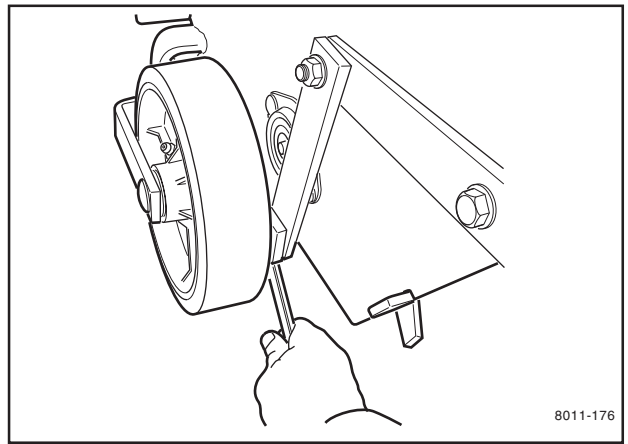

5. Tines

Cover the tines with a thin coat of oil to avoid rust. This is particularly important prior to winter storage or if the machine will not be used for a period of longer than 30 days.

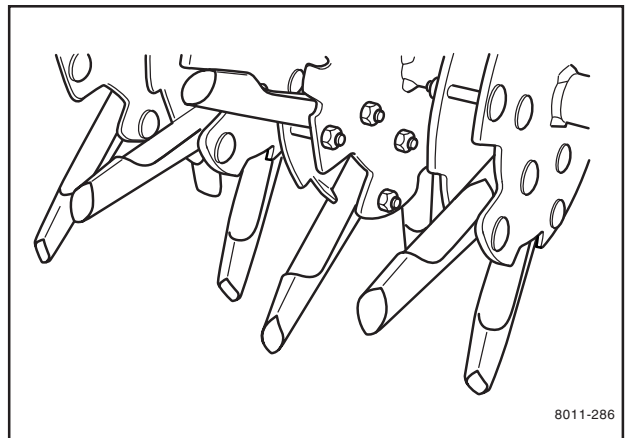

6. Links and joints

It is important to lubricate all links and joints so that they do not bind. Use 30W engine oil.

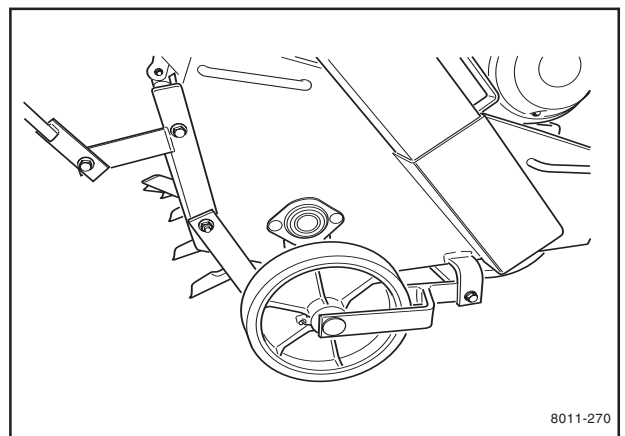

LUBRICATION

7. Adjustment for rear wheel depth/stability

Lubricate the threads regularly with grease to avoid binding or locking. It is particularly important to lubricate the threads after cleaning.

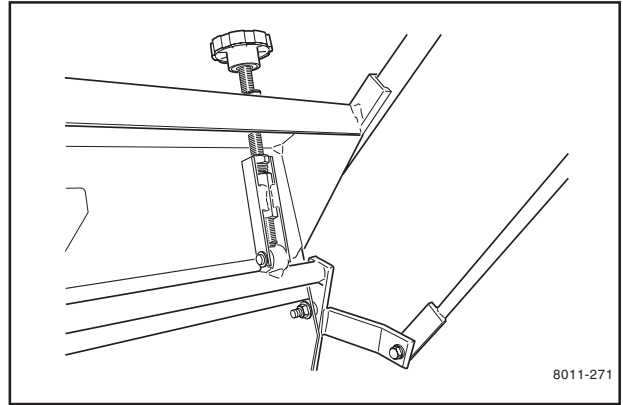

8. Cam lock for the handle

Lubricate the edge of the cam with a little grease.

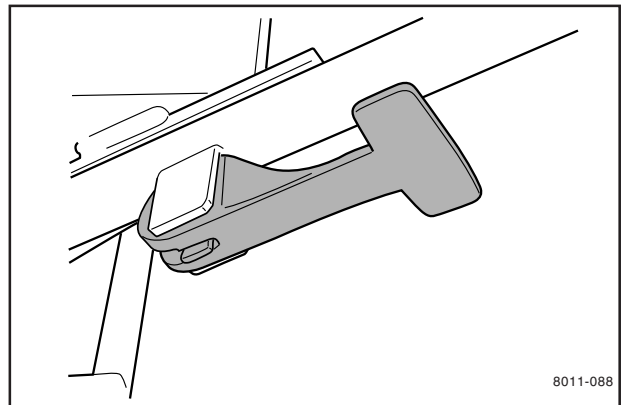

9. Handles with controls

Grease joints with an oilcan (the illustration shows AR25).

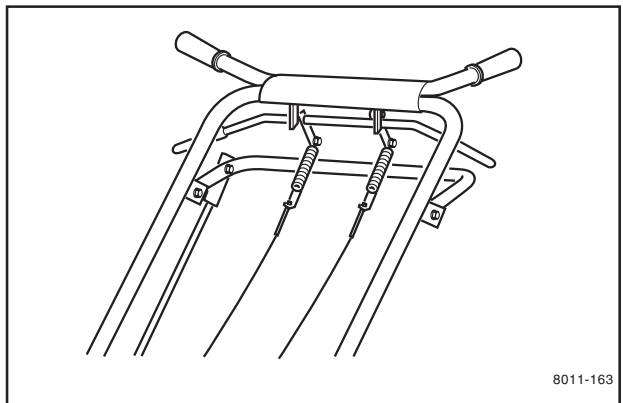

ASSEMBLY INSTRUCTIONS

Assembly – Initial start-up

Applies to model AR19.

1. Use eye protection. Remove the wooden blocks.
2. Carefully cut along the side of the box.
3. The lawn aerator is delivered with the handle collapsed. First lift the rear wheel control (4) and then fold the collapsible handle (3) into working position. Lock using the cam lock (6).
4. Fill the engine (1) with the manufacturer-recommended oil. See the chapter "Lubrication/ Engine oil".
Fill the reduction gear (2) with the manufacturer-recommended oil. See the chapter "Lubrication/ Oil change in reduction gear". The machine must be parked on level ground when inspecting and filling oil.
5. Place the weights (7) in their holders on each side of the machine.
6. Make sure that the clutch handle releases properly and that the clutch cable slides easily.

IMPORTANT INFORMATION
Be careful for nails and slivers.

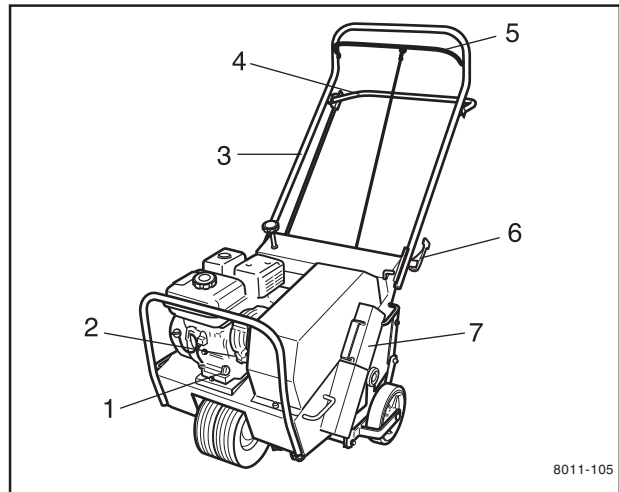

ASSEMBLY INSTRUCTIONS

Applies to model AR25.

1. Use eye protection. Remove the wooden blocks.

IMPORTANT INFORMATION
Be careful for nails and slivers.

2. Carefully cut along the side of the box.
3. The lawn aerator is delivered with the handle removed. Fit the handle using two wrenches (13 mm).
4. Slide the handle onto the mountings (see the top illustration). Affix the handle on the mountings using fittings A (see the bottom illustration).
5. Fit the upper part of the control rod (3 on the top illustration) to the rear wheel control (4 on the top illustration) using fittings B (see the bottom illustration).
6. Affix the lower part of the control rod to the outer side of the torque arm mounting (1 on the bottom illustration) using fittings C (see the bottom illustration).
7. Connect the clutch cable by threading it through the guide hole (6 on the top illustration) at the back of the machine.
8. The lower end of the throttle cable (2) is factory-installed. Insert it through the guide hole (8 in the top illustration) and affix the spring for the throttle/clutch (5 on the upper illustration).
9. Fill the engine with the manufacturer-recommended oil. See the chapter "Lubrication/Engine oil".
Fill the reduction gear with the manufacturer-recommended oil. See the chapter "Lubrication/Oil change in reduction gear". The machine must be parked on level ground when inspecting and filling oil.
10. Put the weights in the compartments on the sides of the machine.

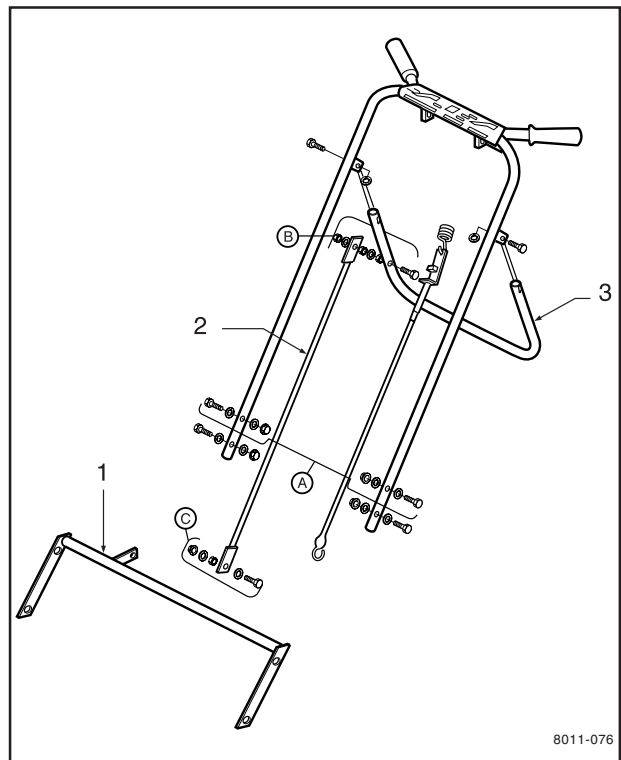
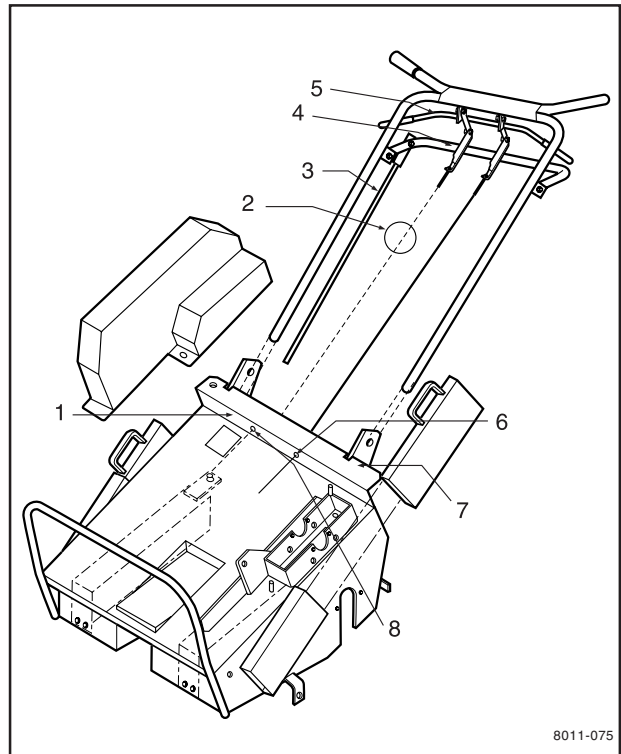

STORAGE

Winter storage

At the end of the season, the machine should be readied for storage (or if it will not be in use for longer than 30 days). Fuel allowed to stand for long periods of time (30 days or more) can leave sticky residues that can plug the carburetor and disrupt engine function.

Fuel stabilizers are an acceptable option as regards sticky residues during storage. If alkylate gasoline (Aspen) is used, stabilizers are unnecessary because this fuel is stable. However, you should avoid switching between regular and alkylate gasoline as sensitive rubber components can harden. Add stabilizer to the fuel in the tank or in the storage container. Always use the mixing ratios specified by the manufacturer of the stabilizer. Run the engine for at least 10 minutes after adding the stabilizer so that it reaches the carburetor. Do not empty the fuel tank and the carburetor if you have added stabilizer.



WARNING!

Never store an engine with fuel in the tank indoors or in poorly ventilated spaces where fuel vapor can come in contact with open flame, sparks or a pilot light such as in a boiler, hot water tank, clothing drier, etc. Handle the fuel with caution. It is very flammable and careless use can cause serious damage to person and property. Drain the fuel into an approved container outdoors and far away from open flame. Never use gasoline for cleaning. Use a degreaser and warm water instead.

Service

When ordering spare parts, please specify the purchase year, model, type, and serial number.

Always use genuine Husqvarna spare parts.

An annual check-up at an authorized service workshop is a good way to ensure that your machine performs its best the following season.

To ready the machine for storage, follow these steps:

1. Clean the machine carefully, particularly the chassis and working equipment. Mend damage to the paint to prevent rust.
2. Inspect the machine for worn or damaged parts and tighten any nuts or screws that may have become loose.
3. Change the engine oil; dispose of properly.
4. Open the fuel valve. Empty the fuel tank (1) and the carburetor (2).

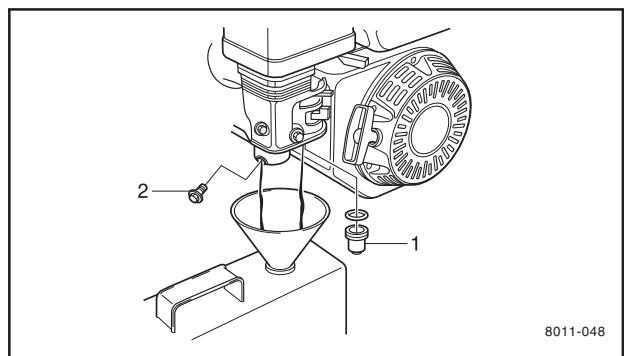

5. Close the fuel valve.
6. Remove the spark plug and pour about a tablespoon of engine oil in the cylinder. Turn over the engine so that the oil is evenly distributed and then refit the spark plug. Put the engine in the compression phase where the triangle mark on the sleeve of the starter is aligned with the upper hole in the starter. Note: Compression phase occurs every second revolution.

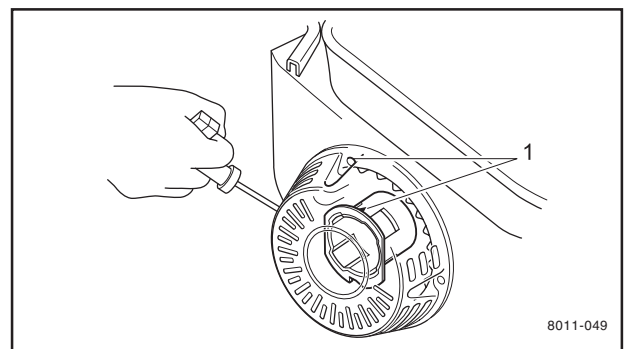

7. Lubricate all grease nipples, joints and shafts as described in the chapter "Lubrication/Lubrication schedule".
8. Store the machine in a clean, dry place and cover it for extra protection.

WIRING DIAGRAM

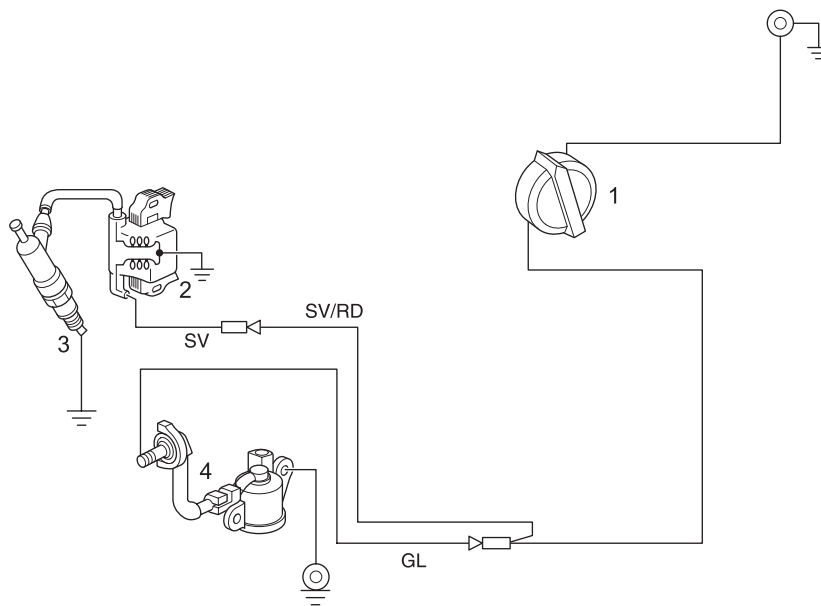
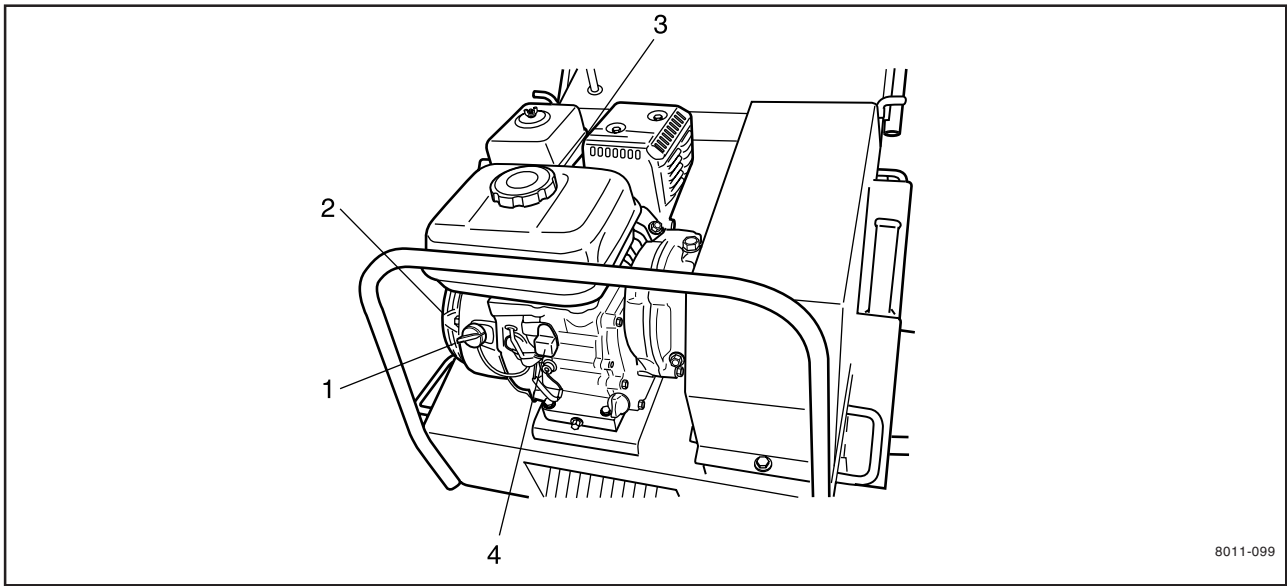

8011-050

1. Engine switch
2. Transistor ignition unit
3. Spark plug
4. Oil level guard

Legend for color abbreviations in wiring diagram

RD = Red
SV = Black
GL = Yellow

TROUBLESHOOTING

Symptom	Cause	Action
The engine will not start		
• User error	Fuel valve closed.	Open the fuel valve.
	Choke valve open.	Close the choke with cold engine.
• Fuel system	Engine switch in OFF position.	Turn the engine switch to ON.
	Fuel tank empty.	Fill with fuel.
	Machine stored without observing proper procedure from chapter "Storage/Winter storage".	Clean tank, sludge reservoir and empty carburetor. Fill the tank with fresh fuel.
• Spark plug	Contamination, water or ice in fuel system.	Clean tank, sludge reservoir, fuel lines and carburetor. Fill the tank with fresh fuel.
	Carburetor problems.	Contact an authorized service workshop.
	Wrong spark plug type.	Replace the spark plug.
• No spark after checking spark plug	Build-up on electrodes. Short circuit.	Check electrode gap and clean or replace spark plug.
	Gasoline or oil on the spark plug.	Clean the spark plug. Air the engine out. Start with full throttle.
• Low compression	Faulty engine switch, cable or ignition.	Contact an authorized service workshop.
• Low compression	Serious interior engine damage or faulty valves.	Contact an authorized service workshop.
Engine is gutless or runs unevenly		
• Air filter	Clogged air filter.	Clean or replace the air filter.
• Fuel system	Machine stored without observing proper procedure from chapter "Storage/Winter storage".	Clean tank, sludge reservoir and empty carburetor. Fill the tank with fresh fuel.
(Blue exhaust)	Tank filled with 2-cycle mixed oil.	Fill the tank with proper fuel.
(Voluminous blue-white exhaust)	Tank filled with diesel.	Clean tank, sludge reservoir and empty carburetor. Fill the tank with proper fuel.
(Black exhaust)	Choke left on.	Open choke valve.
	Clogged air filter.	Clean or replace the air filter.
	Carburetor problems.	Contact an authorized service workshop.
• Ignition system	Wrong spark plug type.	Replace the spark plug.
	Build-up on electrodes. Short circuit.	Check electrode gap and clean or replace spark plug.
	Faulty ignition unit.	Contact an authorized service workshop.
• Low compression (possible blue exhaust)	Serious interior engine damage or faulty valve.	Contact an authorized service workshop.

TECHNICAL DATA

Engine unit	AR19	AR25
Engine	Honda GX120	Honda GX120
Cylinder volume	119 cm ³ (7.3 cu in)	119 cm ³ (7.3 cu in)
Power	4 hp (3 kW) at 3600 RPM	4 hp (3 kW) at 3600 RPM
Torque	7.4 Nm at 2500 RPM	7.4 Nm at 2500 RPM
Spark plug	NGK BPR6ES DENSO W20EPR-U	NGK BPR6ES DENSO W20EPR-U
Idling speed	1250–1400 RPM	1250–1400 RPM
Fuel tank volume	2.5 liters/0.66 US Gal	2.5 liters/0.66 US Gal
Reduction gear	1:6	1:6
Clutch	Belt tensioning	Belt tensioning
Primary drive	One V-belt (A-44")	One V-belt (A-44")
Secondary drive	Chain	Chain
Wheels		
Bearing, front	1.95 cm sealed ball bearing	1.95 cm sealed ball bearing
Bearing, rear	1.95 cm roller bearing	1.95 cm roller bearing
Rear tire	8 x 2" solid rubber	8 x 2" solid rubber
Front tire	10 x 6" half solid tire	10 x 6" half solid tire
Aeration		
Tines	1.95 cm coring 30 per unit	1.95 cm coring 42 per unit
Aeration breadth	48.3 cm	64.8 cm
Coring pattern	9.7 x 16.5 cm	9.7 x 16.5 cm
Coring (aeration) depth	Up to 7.6 cm	Up to 7.6 cm
Holes per m ²	82.9	87.2
Working speed	76.2 m/min (4.57 km/h)	88.39 m/min (5.3 km/h)
Capacity	Up to 2300 m ² /h	Up to 3700 m ² /h
Weight		
Net weight	130.6 kg	190.5 kg
Transport weight	161 kg	221 kg
Removable weights	2 x 16.3 kg	2 x 16.3 kg
Dimensions		
Height	94 cm with the handle collapsed	71 cm without handle
Total height	131 cm	132 cm
Length	100.5 cm with the handle collapsed	84 cm without handle
Total length	146 cm	137 cm
Width	76 cm	96.5 cm (79 cm without wheels)
Transport packaging on delivery	104.1 x 86.4 x 76.2 cm	104.1 x 86.4 x 76.2 cm

Sound - Model AR19

L_{wa}
98.3

Sound Test

Sound test conducted was in accordance with 79/113/EEC and was performed on 8 March 95 under the conditions listed.

L_{pA}
87
OPERATOR

General Condition: Partly Cloudy
Temperature: 52°F (11,1°C)
Wind Speed: 10 MPH (16 kmh)
Wind Direction: S.W.
Humidity: 36%
Barometric Pressure: 24.9" Hg (631 mm Hg)

8011-156

Vibration - Model AR19

0.1g

Vibration Level

Vibration level at the operators handles were measured in the vertical, lateral, and longitudinal directions using calibrated vibration test equipment.

Tests were performed on 8 March 95 under the conditions listed:

General Condition: Partly Cloudy
Temperature: 52°F (11,1°C)
Wind Speed: 10 MPH (16 kmh)
Humidity: 36%
Barometric Pressure: 24.9" Hg (631 mm Hg)

8011-157

Sound - Model AR25

L_{wa}
99.1

Sound Test

Sound test conducted was in accordance with ISO 11094:1991 and was performed on 4 April 97 under the conditions listed.

L_{pA}
84.7
OPERATOR

General Condition: Partly Cloudy
Temperature: 65°F (18,3°C)
Wind Speed: <5 MPH (8 kmh)
Wind Direction: N/A
Humidity: 45%
Barometric Pressure: 24.7" Hg(626 mm Hg)

8011-158

Vibration - Model AR25

0.6g

Vibration Level

Vibration level at the operators handles were measured in the vertical, lateral, and longitudinal directions using calibrated vibration test equipment.

Tests were performed on 4 April 97 under the conditions listed:

General Condition: Partly Cloudy
Temperature: 65°F (18,3°C)
Wind Speed: <5 MPH (8 kmh)
Humidity: 45%
Barometric Pressure: 24.7" Hg (626 mm Hg)

8011-159

114 00 28-26



2001W35